

Rivorm[®]

Clinch fasteners for different assembly jobs

- ⊕ for fitting ties and springs
- ⊕ can be processed in many sheet strengths
- ⊕ fully automated processing possible in the subsequent composite tool
- ⊕ application as positioning and assembly aid

➔ www.arnold-fastening.com



Rivorm® HR rivet nuts – One for every strength and sheet thickness

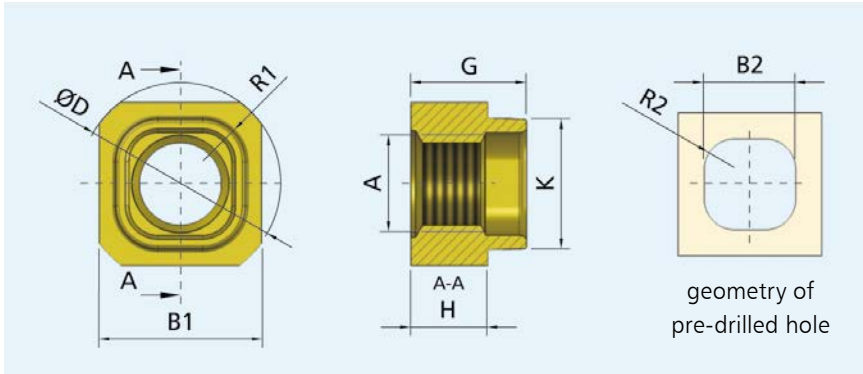

Technical data

Metal thickness	0.4 – 3.5 mm (4.5 mm)
Strength class	8 and 10
Surface	as required

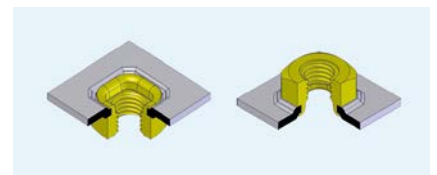

HR RIVORM® rivet nut dimensions

Dimension	A	B1	Ø D	G	H	K	R1	Dimensions of pre-drilled hole geometry	
								B2	R2
Tolerance		±0.1	min.	+0.1 / -0.3	±0.1	-0.2		-0.1	-0.1
HR 5	M5	12.72	15.60	9.00	5.00	9.70	R3	10.00	R3
HR 6	M6	12.72	15.60	9.00	5.00	9.70	R3	10.00	R3
HR 8	M8	15.52	19.30	10.50	6.50	11.90	R4	12.30	R4
HR 10	M10	16.80	20.60	12.00	8.00	13.60	R4.5	14.00	R4.5
HR 10A	M10	18.80	22.60	12.00	8.00	13.60	R4.5	14.00	R4.5
HR 12	M12	20.80	25.40	14.00	10.00	16.00	R4.7	16.40	R4.7
HR 12A	M12	20.80	25.40	16.50	10.00	16.00	R4.7	16.40	R4.7
HR 12B	M12	23.80	27.00	13.00	7.50	16.00	R4.7	16.40	R4.7
HR 7/16	7/16-20 NF	20.80	25.40	14.00	10.00	16.00	R4.7	16.40	R4.7

The benefits of the Rivorm® HR rivet nut

- ⊕ one nut for any thickness of sheet metal up to 4.5 mm
- ⊕ cost-saving because fewer variants
- ⊕ high-strength, press-hardened and hot-stamped steels
- ⊕ very good torsional strength regardless of metal strength
- ⊕ high pull-out force
- ⊕ ARNOLD processing technology for process-reliable and cost-optimised production
- ⊕ existing ARNOLD processing technology for other nut types can be altered at little cost (and permanently) to convert to HR nuts
- ⊕ also available in stainless steel

The solution for almost every material, for example:

- ⊕ high-strength sheet metals
- ⊕ composite materials
- ⊕ CFRP
- ⊕ Magnesium

Note: The values stated are examples. The actual values must be determined separately for the application in question.

Function sequence

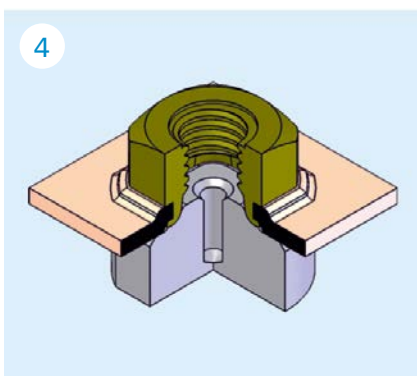
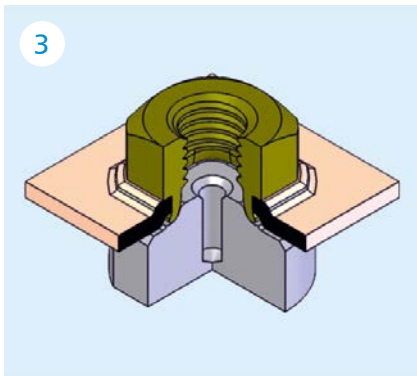
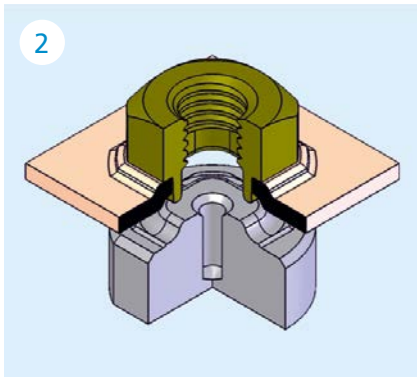
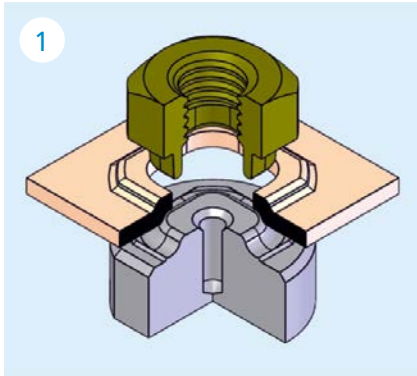

Pull-out and torque values

(material 22 MnB5, press-hardened 49HRC)

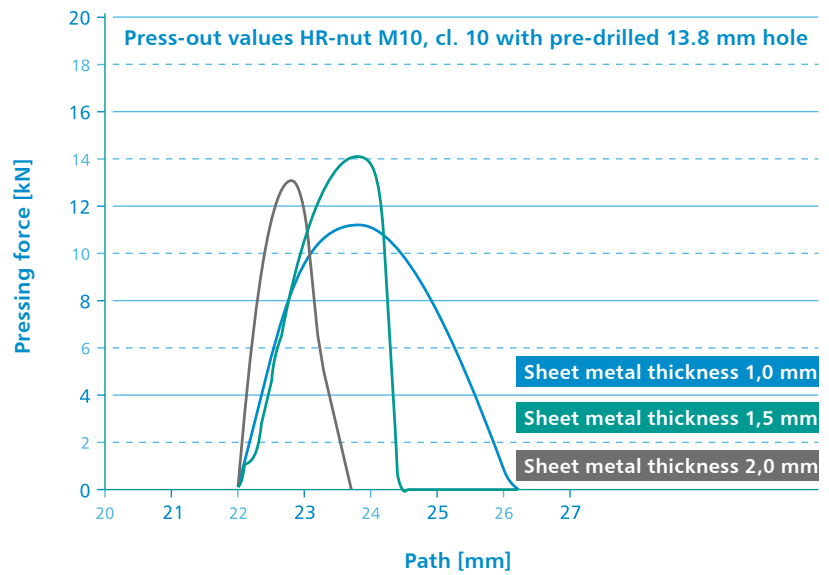
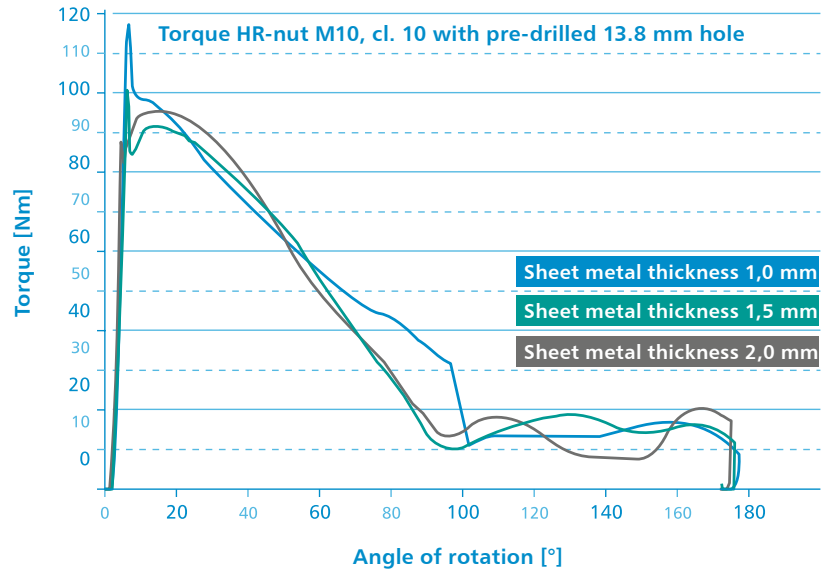

Can be applied universally for different assembly jobs

Rivorm® TR rivets – Suitable for many applications

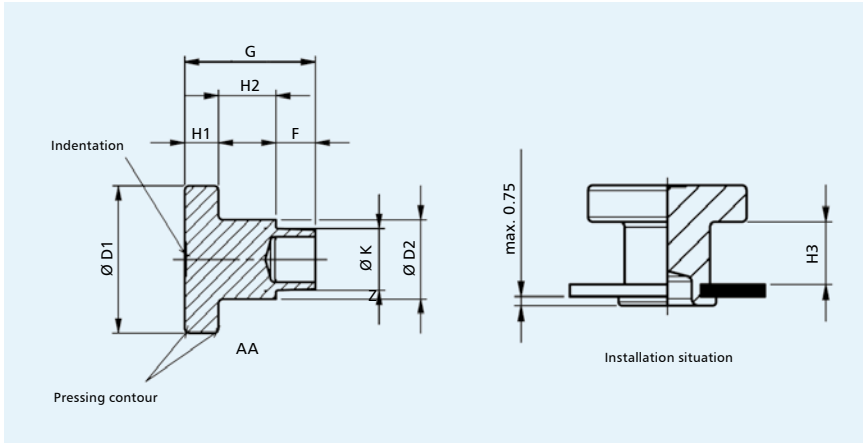

Technical data

Dimensions	10 x 6 bis 16 x 8
Strength class	8
Surface	as required

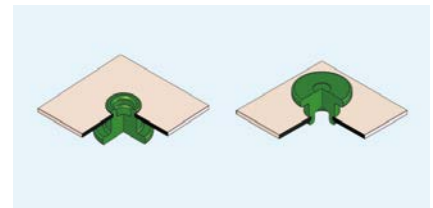

Dimensions of RIVORM® TR rivets

	Ø D1	Ø D2	Ø K	H1	H2	F	G	Hole Ø in plate	H3	Thickness of metal in mm
	± 0.1	± 0.1	- 0.15		± 0.1	- 0.2	- 0.2	+ 0.1		
TR 10 x 6	10.0	6.0	4.9	(1.5)	3.0	2.0	6.5	5.0		0.4-1.5
	± 0.2	± 0.1	-0.15	± 0.2	+0.2	± 0.1		+0.1	+0.2	
TR 11 x 6	11.0	6.0	4.5	3.0	5.1	3.5	(11.6)	4.6	5.0	0.4-2.5
TR 13 x 7	13.0	7.0	5.5	3.0	5.1	3.5	(11.6)	5.6	5.0	0.4-2.5
TR 16 x 8	16.0	8.0	6.0	3.0	7.6	3.5	(14.1)	6.1	7.5	0.4-2.5

Other dimensions available on request.

The benefits of the Rivorm® TR rivet

- ⊕ for fitting ties and springs
- ⊕ fully automated processing possible in the subsequent composite tool
- ⊕ can be applied universally for different assembly jobs, such as fastening electrical control units, or other plastic parts, simply by clipping them in
- ⊕ can be processed in all metal strengths
- ⊕ application as positioning and assembly aid

Note: The values stated are examples. The actual values must be determined separately for the application in question.

Function sequence

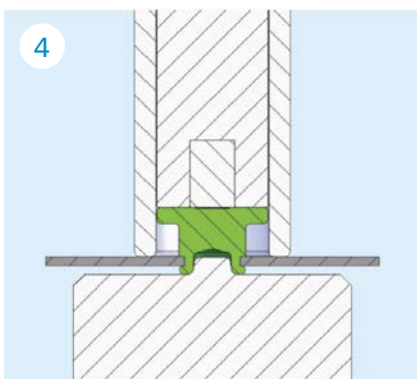
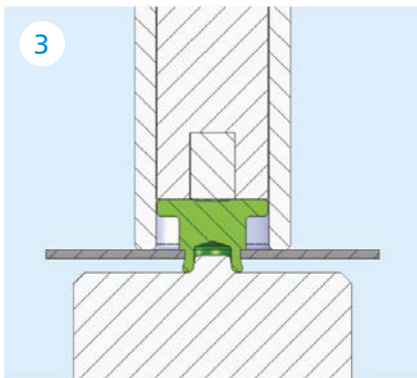
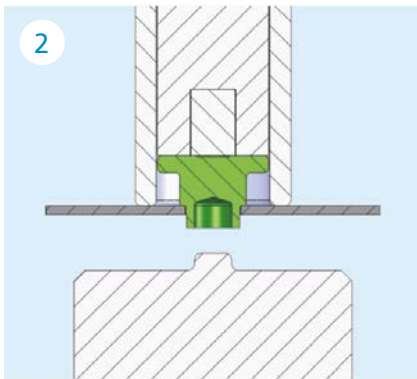
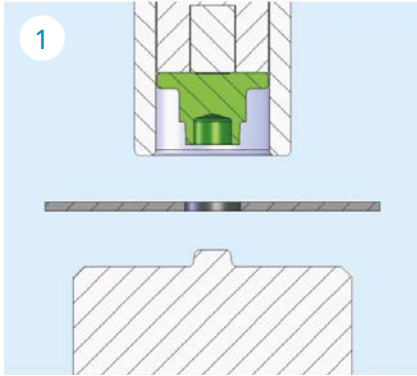

Rivorm® AX rivet – our rivet with additional function

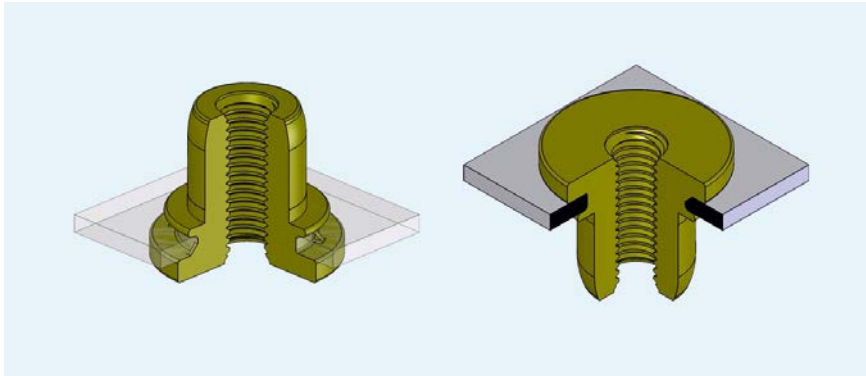

Function sequence

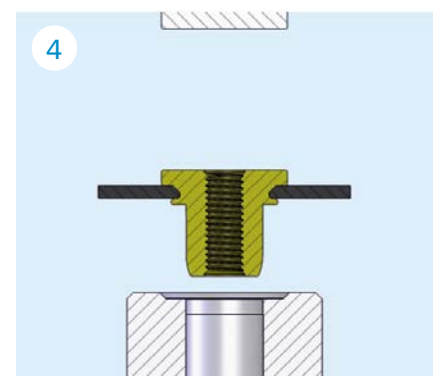
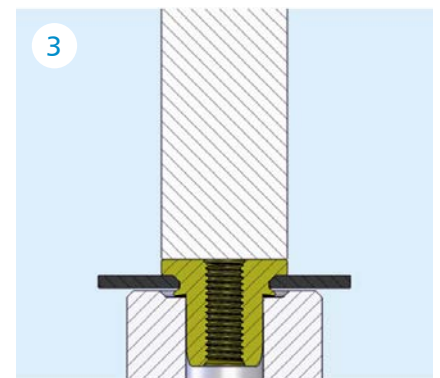
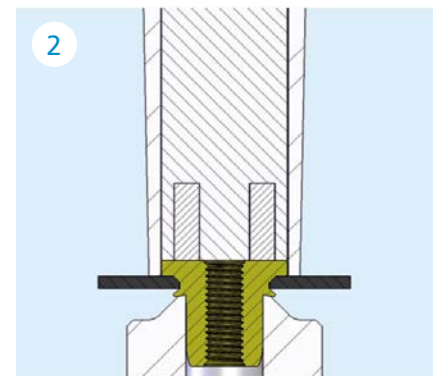
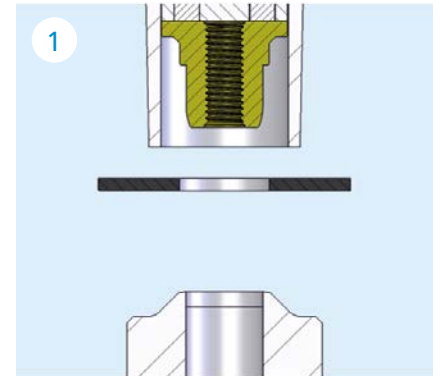

By patenting the innovative fastening method into metals, with the Rivorm® AX rivet, ARNOLD & SHINJO is providing another customised fastening solution. In applications with integral functionality, such as bearing seating, assembly aid or spacer, the new product line from Dörzbach has already proved itself in several series applications. Depending on the geometrical design of the rivet, the Rivorm® AX rivet is setting new standards of strength between fastener and sheet metal. Moreover, it can be used to fasten a wide range of metal thicknesses.

How the fastener functions

The material is peeled and a collar formed so that a flush and positive fit of the fastener is created with the sheet metal material. This can either transfer very high forces (e.g. AX 20x14) or with the version that is flush with the sheet, the fastener can be used to directly mount connected parts (e.g. AX 16x4). This principle can be applied to almost every material.



The ARNOLD GROUP

Wherever customers need us.

The ARNOLD GROUP

With a foundation of many years of expertise in the production of intelligent fastening systems and very complex extruded parts, the ARNOLD GROUP has developed over a number of years into a comprehensive supplier and development partner for complex fastening systems. With our new positioning of "BlueFastening Systems" this development process will now continue under a united and harmonised structure. Engineering, fastenings, and functional parts, together with feeder processing systems, all from a single source – efficient, sustained and international.



ARNOLD FASTENING SYSTEMS

Rochester Hills
USA



ARNOLD TECHNIQUE FRANCE

Anneyron
France



ARNOLD UMFORMTECHNIK

Ernsbach
Germany



ARNOLD UMFORMTECHNIK

Dörzbach
Germany



ARNOLD FASTENERS SHENYANG

Shenyang
China

ARNOLD UMFORMTECHNIK GmbH & Co. KG

Carl-Arnold-Straße 25
D-74670 Forchtenberg-Ernsbach
T +49 7947 821-0
F +49 7947 821-111

ARNOLD FASTENING SYSTEMS Inc.

1873 Rochester Industrial Ct, Rochester Hills, MI 48309-3336, USA
T +1 248 997-2000
F +1 248 475-9470

ARNOLD TECHNIQUE FRANCE S.A.

4, rue St Didier
F-26140 Anneyron
T +33 475 313260
F +33 475 314440

ARNOLD FASTENERS (SHENYANG) Co., Ltd.

No. 119-2 Jianshe Road
CN-110122 Shenyang
T +86 24887 90633
F +86 24887 90999