



Container Mixer i4

The mixer concept in the era of Industry 4.0 and IoT

EASIEST CLEANING | MAXIMUM FLEXIBILITY

The advantages of the MIXACO Container Mixer i4

MIXACO has been innovation leader in the mixing industry for more than 50 years. Many of our inventions and patents were developed together with our customers and became an industry-wide standard.

Short delivery times, frequent recipe changes, decreasing batch sizes, innovative recipe components, and high quality standards as a matter of course are only some of the challenges that our customers face on a daily basis. These challenges take on an ever-increasing importance in the era of Industry 4.0 / IoT.

For this reason, we developed the Container Mixer i4 together with our customers. High flexibility, minimum cleaning effort, maximum machine availability, and optimal machine efficiency are the features that characterize the MIXACO Container Mixer i4.

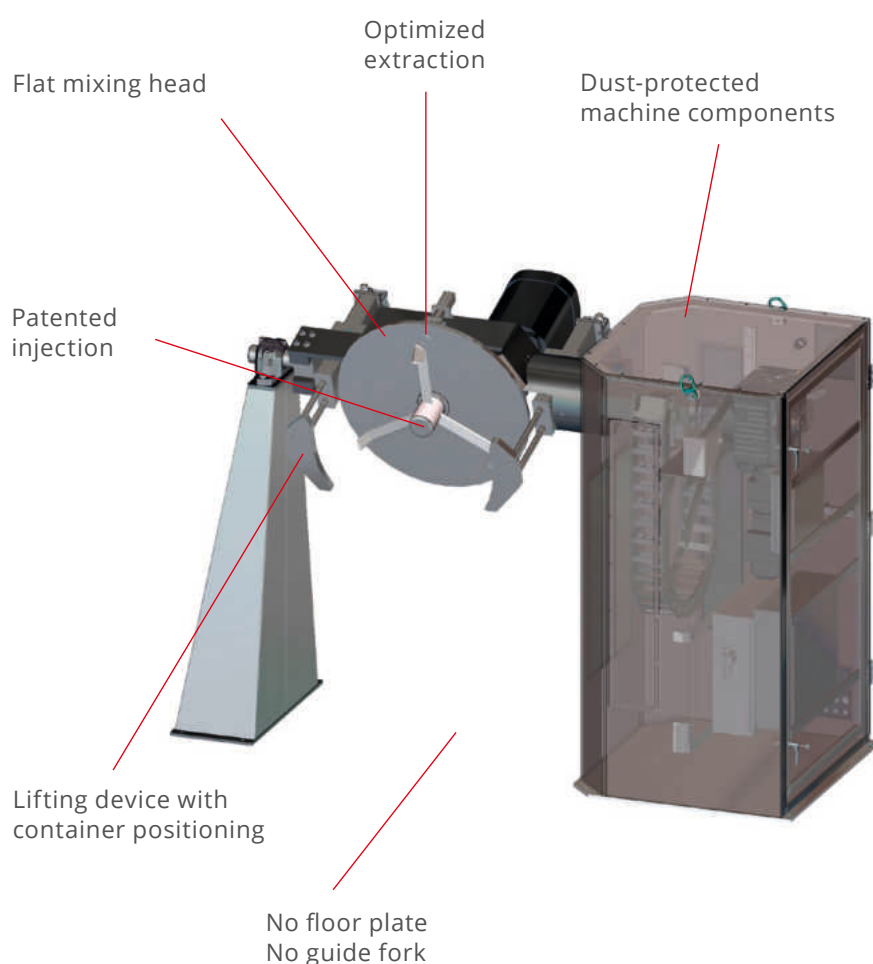

The advantages of the i4

- One mixer for different container sizes
- Cleaning effort reduced to a minimum
- Maximum flexibility for different batch sizes
- Maximum efficiency with frequent recipe changes
- Fast response times for continuously shorter delivery times
- Moderate temperature increase thanks to low circumferential speeds (4 – 15 m/s)
- Excellent mixing quality at short mixing times
- Innovative injection of liquids through the shaft
- Minor wear at mixing tool and at mixing head
- High energy efficiency through the use of frequency-controlled energy-efficient motors

Equipped with the new MIXACO Control Center (MCC), we are setting a new milestone for high-efficiency mixing equipment.

Details

No floor plate

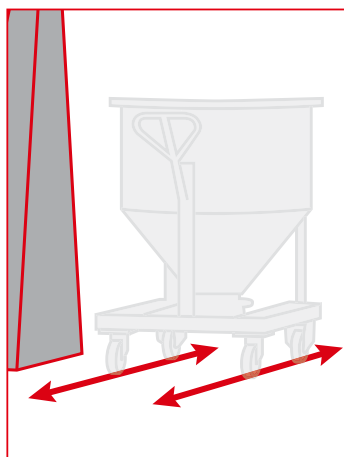

Omitting the floor plate reduces additional cleaning effort.

Flat mixing head

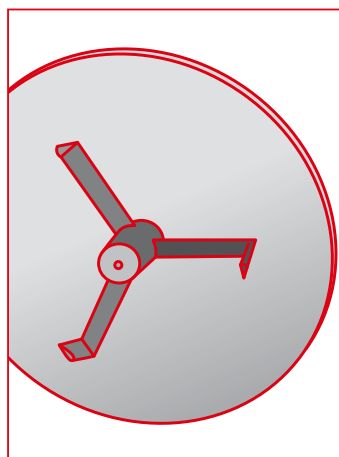

The flat design of the mixing head has a smaller surface and, as such, can be cleaned faster and easier.

Dust-protected machine components

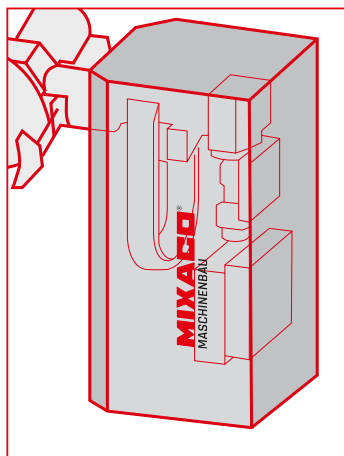

The dust-protected machine components also contribute to lower maintenance cycles as well as minimum need for cleaning.

Dedusting

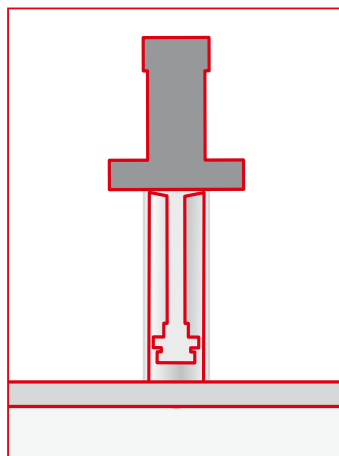

Dedusting equipment on the mixing head that extracts the fine dust generated in the mixing container after the mixing process.

EX protection ATEX/NEC

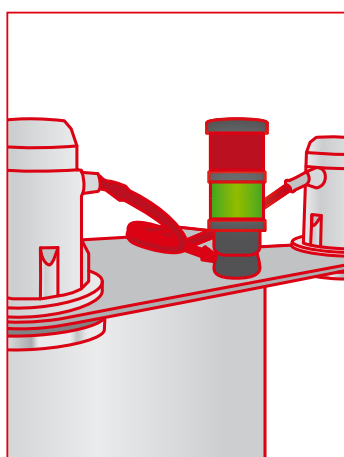

The container mixer can be designed in compliance to ATEX for the operation of potentially explosive applications according to customer specifications.

Temperature sensor in the mixing head

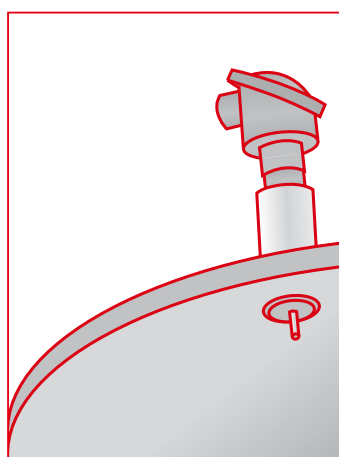

Temperature sensor in the mixing head to determine the product temperature during mixing. The temperature is indicated on the operating panel.

Tool i4

Best mixing quality for a wide variety of applications

MASTERBATCHES | COLOR MIXING | ADDITIVES | POWDER COATING | TONER | FOOD | ANIMAL FOOD | AND MUCH MORE

The MIXACO mixing tool i4 was developed specifically for use in a mixer with a flat mixing head. The innovative design of the i4 tool enables a good mixing vortex formation, even at moderate circumferential speeds. Depending on the application, these speeds range from 4 to 15 m/s. An outstanding homogenization and excellent color output are guaranteed.

Given the large distance to the mixing head bottom, the tool can be cleaned while it is installed. The large distance to the mixing head and also to the container as well as the innovative geometry of the i4 tool minimize material build-up, which also results in a significant reduction of cleaning.



The advantages of the new i4 tool

- Short mixing times with outstanding homogenization of the material
- Moderate temperature increase thanks to low circumferential speeds (4 – 15 m/s)
- Minimum product build-up due to innovative tool geometry and large distances to the mixing head and container
- Cleaning the tool and the mixing head can be done while the tool is installed

One mixer – three sizes

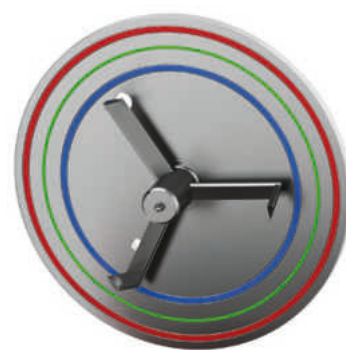

600 L



450 L



300 L

- Lower investment volume
- Flexible batch size and recipe change
- No conversion of the mixing head required
- Use of existing containers is possible
- Gaskets are attached to the container

Control

Our mixing equipment is controlled with a Siemens S7 PLC and meets today's requirements for safety, efficiency and cost-effectiveness. Since the control is developed and programmed by one and the same company, it is virtually ensured that the mixer components are optimally integrated. As an alternative, it is also possible to use Allen-Bradley components (incl. Panelview operating unit). Control can also be designed according to UL / NEMA. Additionally, the control can be equipped with an interface for data exchange with higher-level control.

Siemens TP700

- Using the touch control panel TP700, up to 99 mixing programs can be created in table form with ten work steps each.
- Data recording and storing measured values

Allen Bradley

- Control according to UL / NEMA standards with an Allen Bradley PLC and a Panelview operating unit

MIXACO Control Center

MACHINE AVAILABILITY | 360° SERVICE | USER-FRIENDLY HMI | TRANSPARENCY
 REAL-TIME AND PROCESS INFORMATION | DATA SECURITY



Machine Dashboard



3D Model

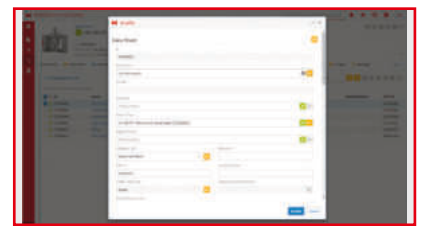

Machine Spare Part List

The remote maintenance module enables quick and safe access to the control of the mixing equipment via a VPN tunnel to facilitate swift troubleshooting and rectification of the issue by our service staff. This prevents service calls on site.

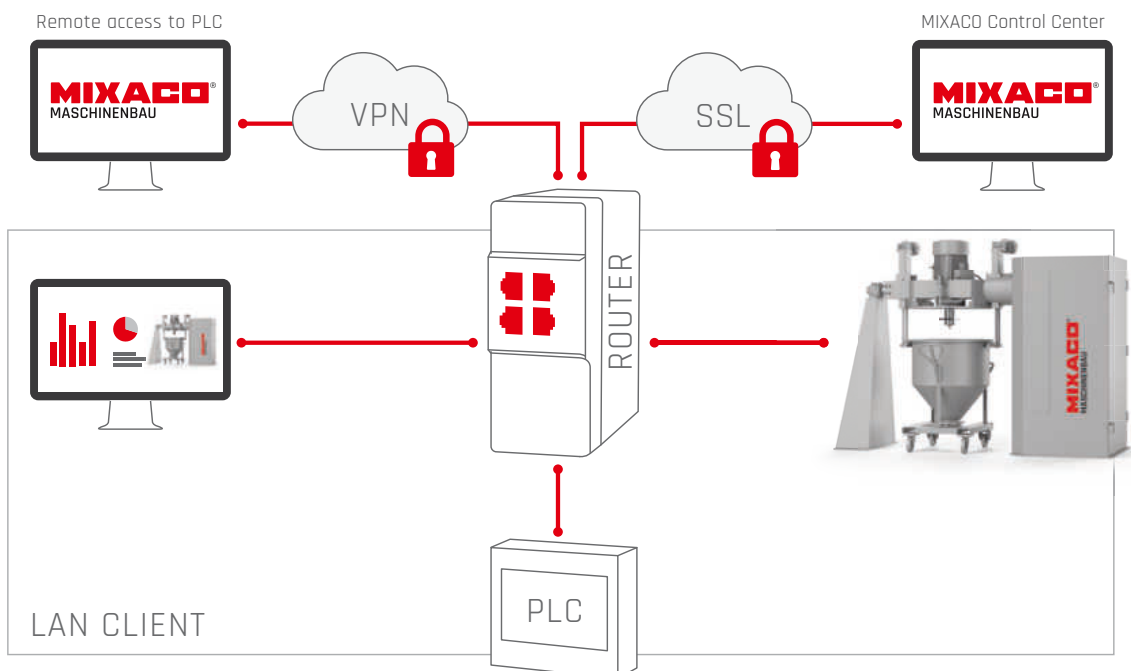

Technical Data

Best mixing quality for a wide variety of applications

MASTERBATCHES | COLOR MIXING | ADDITIVES | POWDER COATING | TONER | FOOD
 ANIMAL FOOD | AND MUCH MORE

Multi-method

For a wide variety of mixing processes:

- Homogenizing
- Wetting
- Dispersing

Maximum functionality

Additional expansion options:

- Three different container sizes possible with a single mixer
- Compatibility with existing systems and containers
- Expanded stainless steel design of the Container Mixer
- Wearing protection for the tools
- Temperature measurement of the mix
- Innovative liquid injection
- Option of adding material in mixing position
- Special painting
- VivateQ® coating
- AGV (automatic guided vehicle) compatibility
- ATEX/NEC execution:
 - Filling level measurement
 - Nitrogen inerting
 - Oxygen concentration measurement
- MIXACO Control Center

Sizes	Usable volume Liters	Batch size kg	Mixing time min / Batch
Lab Container Mixer			
LAB CM 6	4,8	3	3-6
LAB CM 12	9,6	6	3-6
Container Mixer i4			
CM 50	40	24	3-6
CM 150	120	70	3-6
CM 300	240	140	3-6
CM 450	360	210	3-6
CM 600	480	280	3-6
CM 800	640	380	3-6
CM 1000	800	480	3-6
CM 1300	1040	620	3-6
CM 2000	1600	960	3-6

Parameter	
Bulk weight	0.6 kg/l
Fill level	max. 80 %
Loading	manuell
Additional sizes available on request	

Experience in Many Industries

MIXACO has been offering solutions for a wide variety of industries for many decades. This means the requirements on the mixing technology are correspondingly varied. MIXACO has profound expertise across many industries and can precisely and positively adapt the wide product range to each individual mixing solution.

Particularly when it comes to Container Mixers, customers can benefit from comprehensive consultation and the development of customer-specific solutions. Whether new projects or the optimization of existing plants, MIXACO will be at your side up to the successful installation and commissioning.

No other company stands for innovation in mixing technology like MIXACO, who has been setting new standards with its machinery and solutions for decades. Leading companies from numerous industries worldwide trust in MIXACO products.



Powder Coatings



Masterbatches

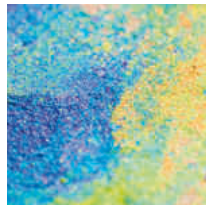

Additives



Paint Industry



Building Materials

Save the Best for Last

All advantages at a glance:

- Maximum flexibility by using different container sizes in a single mixer
- New tool design for an optimal mixing vortex formation at moderate temperature increase
- Large distance of mixing tool to mixing head allows cleaning while it is installed
- Low circumferential speeds (4 – 15 m/s)
- Moderate circumferential speeds reduce product build-up
- More efficient material logistics due to material handling in the mixing container
- User-friendly thanks to ergonomically optimized cleaning in preconfigured cleaning position
- Can be used for a wide variety of mixing tasks with many tool and motor combinations
- Technology and components are also designed for operation across multiple stories

Fast facts

- Highest flexibility
- Optimal homogenization
- Minimal heating of the mix
- Minimal cleaning times
- Short mixing times
- No melting and adhesion

Good ideas are conceived.
But the right solutions are put to the test.



Contact us for your mixing trials and benefit from the extensive experience of our technicians and process engineers:

- Tests on various mixing systems
- Adaptation of mixing parameters
- Recording and documentation of mixing tests
- Analysis of mixing results



MIXACO

Dr. Herfeld GmbH & Co. KG

Niederheide 2
58809 Neuenrade
Germany

Phone +49 2392 9644-0
Fax +49 2392 62013
info@mixaco.de

MIXACO USA LLC

1784 Poplar Drive
Greer, SC 29651
USA

Phone +1 864 331 23 20
Fax +1 864 331 23 21
info@mixaco.com