

Product information

T Pump Series

Submersible pumps
Materials: PP or PVDF
without seals
dry-run-safe

SCHMITT

chemical resistant pumps

Description

T Pump Series



SCHMITT

chemical resistant pumps

Submersible pumps without seals

Application: The T Pump Series is particularly suitable if containers or dipping baths cannot be flange connected to the side or if dry run in the plant cannot be excluded.

Field of application: Wafer production, gas u, exhaust air scrubber, environment engineering, PCB manufacturing, laboratory and medical and pharmaceutical technology, electro-plating technology, semiconductor technology, wastewater treatment, solar cell production, circulation and mixing application

Materials: PVDF (polyvinylidene fluoride) or
PP (polypropylene)

Immersion depth: 200 - 800 mm

Max. output rate: 280 l/min

Max. discharge head: 28 m

Motor power: 0.18 - 5.5 kW

In the T Pump Series, the motor power is transmitted vertically to the pump impeller through an extended shaft. This rotating shaft is exclusively supported through the two motor bearings and therefore runs completely contact free and abrasion-free inside the housing. Due to the design, the use of bearing and shaft seals can be forfeited.

Advantages:

- » absolutely dry run safe (no contact of mechanical parts)
- » highest chemical resistance
- » robust, thick-walled design
- » long-lasting and abrasion-free
- » design for the operation under demanding conditions
- » open impeller (i.e. solids up to 3 mm grain size and 10 Vol. % possible)
- » no abrasion into the medium to be pumped (high purity applications)
- » no metal parts are in contact with the medium
- » easy to maintain
- » universally applicable, quiet and compact
- » various chemical resistant materials can be supplied from the warehouse
- » available for standardized immersion depths

Types

T Pump Series

- Materials and Components:**
- » Parts in contact with the medium are made solid of PVDF, (up to +95° C), or PP (up to +80° C)
 - » Housing seal alternatively made of FKM, EPDM, FEP or Kalrez®
 - » Also with extension pipe and/or with filter basket
 - » High-quality electric motors made in Germany

- Material details:**
- » **PVDF:** Polyvinylidene Fluoride, Pure, milky white, not colored (up to +95° C)
 - » **PP:** Polypropylene, Fiber glass-reinforced, gray (up to +80° C)
 - » **FKM:** Viton® quality, -20...+200° C
 - » **EPDM:** Ethylene propylene diene M-class rubber, Food-safe (FDA, KTW, WRC), -40...+160° C
 - » **FEP:** Fluorinated ethylene propylene with Viton® or silicone core, -60...+200° C
 - » **Kalrez®:** High performance elastomere up to +315° C

Motor details:

- Standard Motors (stock items):**
- » Three-phase motors: 230/400 V 3ph, 50 Hz, IP 55. insulation-class F or 277/480 V 60 Hz also with PTC thermistor
 - » Alternating current motors: 230 V 1ph, 50/60 Hz, IP 55. Insulation class F
- Special design models (available):**
- » Three-phase motors, explosion proof, flameproof enclosure, EEx de II CT4
 - » Special voltages and frequencies
 - » 2-, 4- and 8-pole
 - » UL and CSA execution
 - » Special protection types (e.g. IP 65)
 - » High temperature designs
 - » Special insulation classes (e.g. tropical insulations)
 - » Multi area voltage (e.g. 220-290 / 380-500 V 50 Hz; 220-332 / 380-575 V 60 Hz.)
 - » Additional designs upon enquiry.

Characteristics

T Pump Series

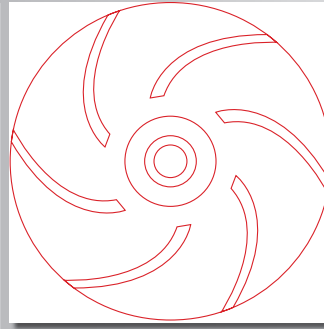

SCHMITT

chemical resistant pumps

T Pump Series	Motor power	ET = depth of immersion
» T 100	0.12 kW	200
» T 115	0.25 kW	200 - 300 - 400
» T 130	0.55 kW	200 - 300 - 400
» T 150	0.75 kW	300 - 400 - 500
» T 170	1.50 kW	400 - 600 - 800
» T 190	2.20 kW	400 - 600 - 800

Characteristic lines measured with water, 20° C and 2900 Rpm (50 Hz.)

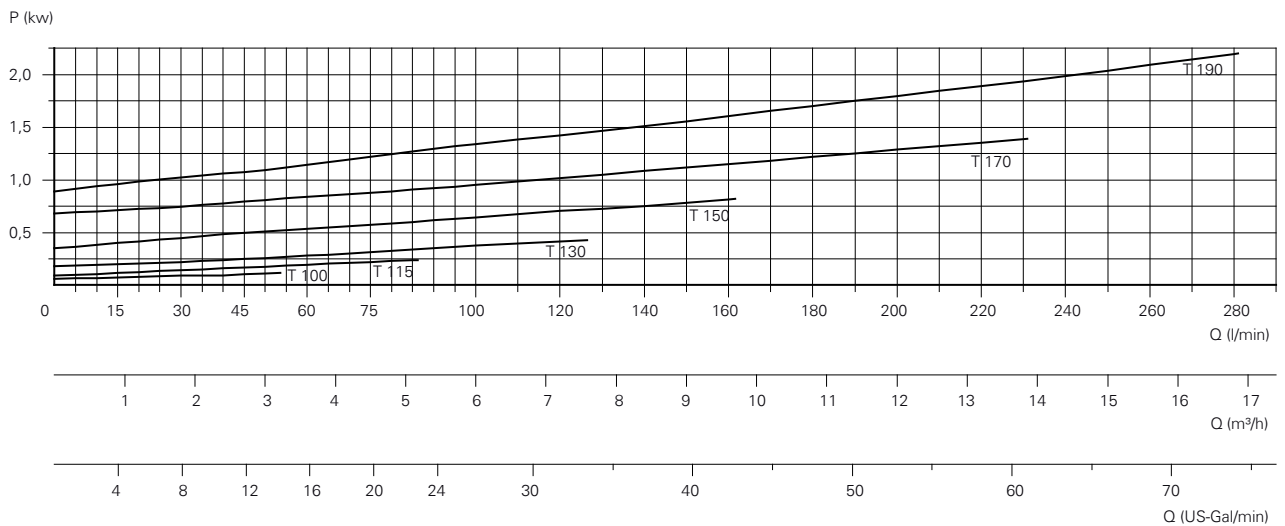
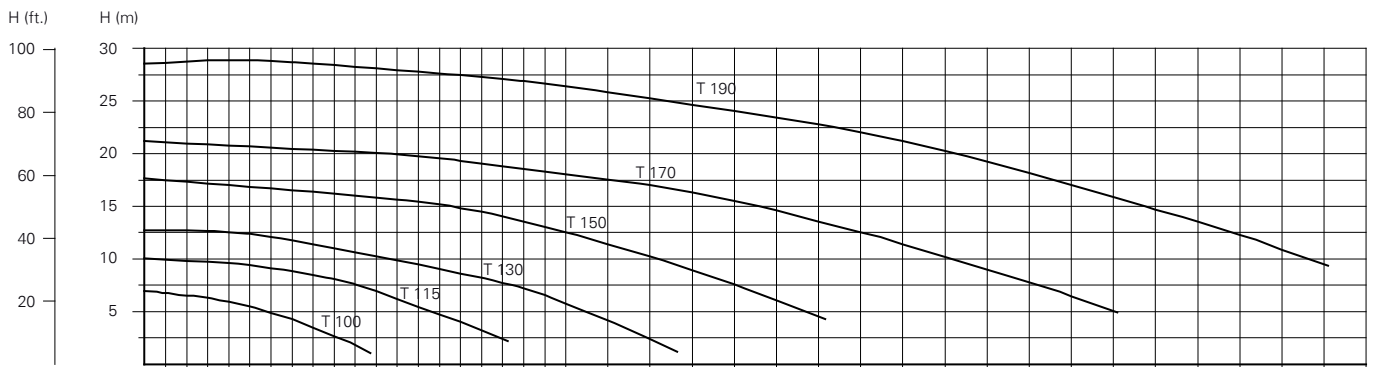

Parts Descriptions

T Pump series

chemical resistant pumps

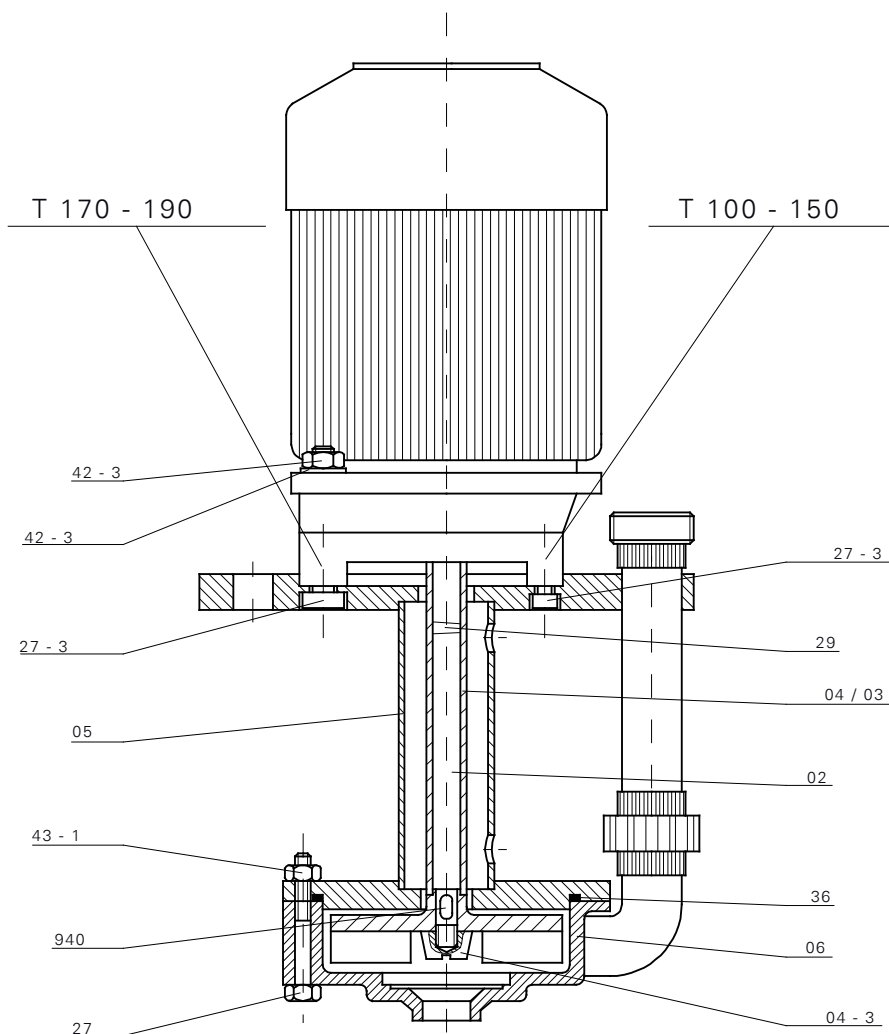

Part-no.	Part	Material standard	on request
02	shaft	Steel	
04-3	cap	PVDF	
04/03	impeller with shaft coating	PP	PVDF
05	support tube	PP	PVDF
06	pump housing	PP	PVDF
27	hexagon bolt	PP*	PVDF
27-3	bolt	A4	
29	cotter pin	1.4305	
36	pump housing seal	FKM**	FEP / EPDM
42-3	washer	A4	
43	hexagon bolt	A4	
43-1	hexagon bolt	PP*	PVDF
940	feather key	1.4305	

*for T 100 -130: PVDF
 **FKM = e.g. Viton®

Specification

T Pump Series

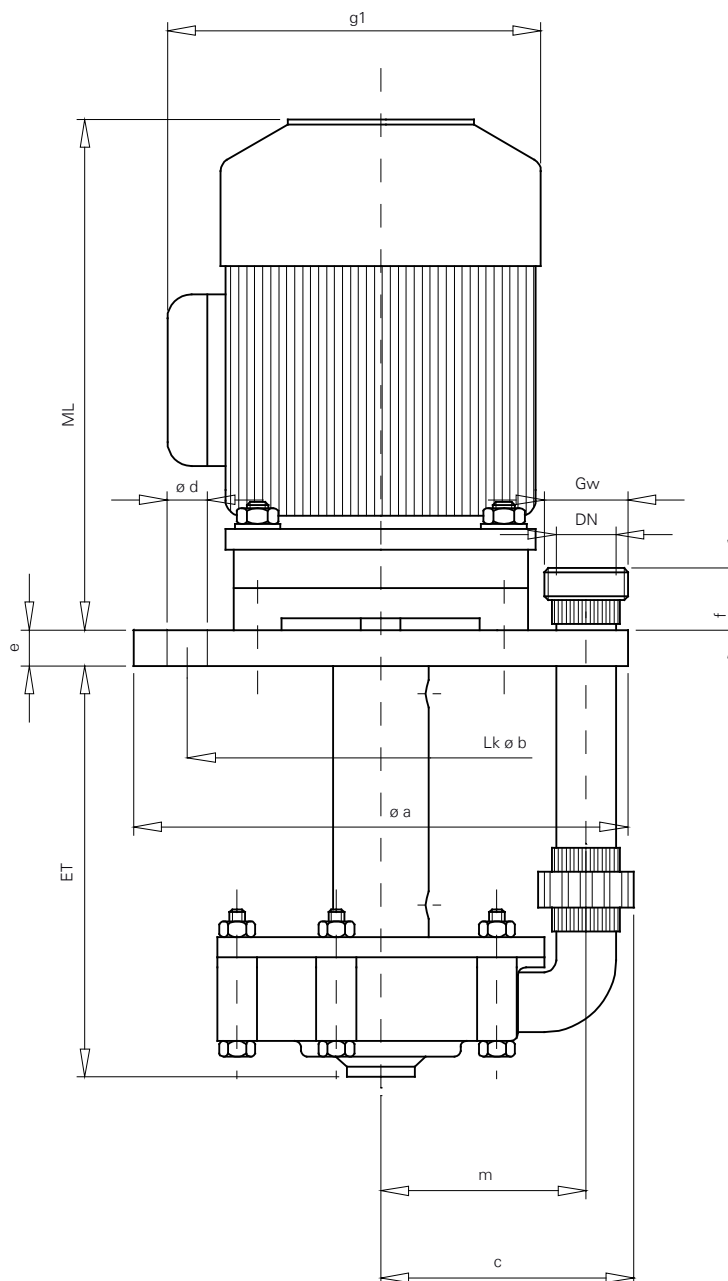

Type	ø a	ø b	c	ø d	e (PP)	e (PVDF)	f	g1	m	ML	Gw	DN
T 100	220	150	119	11	18	18	30	147	90	191	G 1"	15
T 115	230	170	126	11	18	18	30	158	90	211	G1 ¼"	20
T 130	240	200	129	11	18	18	30	182	100	241	G1 ¼"	20
T 150	265	225	142	11	22	18	30	209	113	263	G1 ¼"	20
T 170	320	280	162	13	22	18	55	235	130	278	G1 ½"	25
T 190	330	280	173	13	22	18	55	235	141	303	G1 ½"	25

Dimensions in mm

T Pump Series

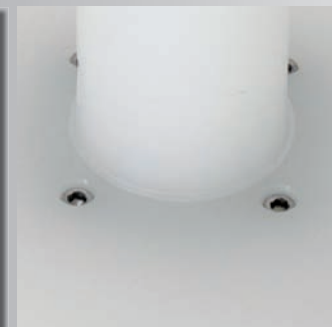

SCHMITT

chemical resistant pumps

- Motors:**
- » all driving motors are to IEC standard operating on 230/400 volts 50 cycles.
 - » single phase A.C. motors are also available up to 1.10 kW.
 - » explosionproof motors can be supplied to the whole range of pumps.
 - » special voltages, frequencies and types of protection can be delivered on request.
 - » upon request all motors can be supplied for USA standard (UL proof).

- Note:**
- » you will find further information about our products and connecting parts as well as manuals and technical recommendations in several languages at our website www.schmitt-pumpen.de

SCHMITT

Kreiselpumpen GmbH & Co.KG

Einsteinstrasse 33

D - 76275 Ettlingen

Phone: +49 - 72 43 - 54 53 - 0

Fax: +49 - 72 43 - 54 53 - 22

info@schmitt-pumpen.de

www.schmitt-pumpen.de



We reserve the right to alter the technical details. Dimensions and performance details without guarantee.

05/2014