

Fiberglass Reinforced Polymer  
**CATALOGUE**

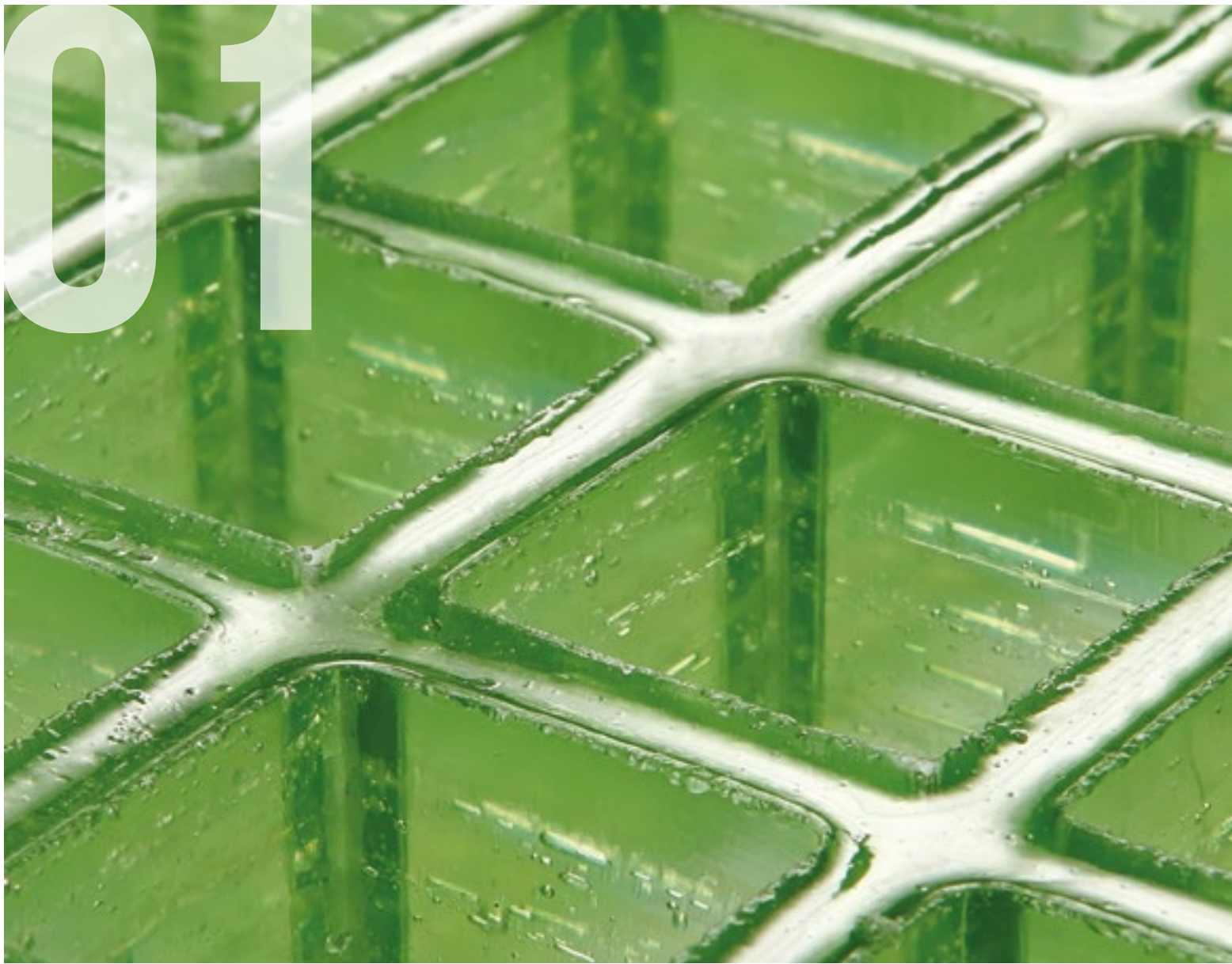

# 01



## SERVICES

### ENGINEERING

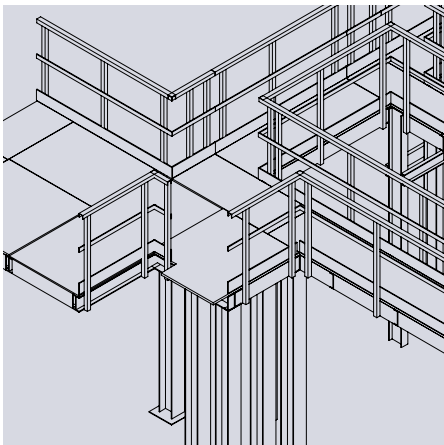

### MECHANICAL TESTS



### CHEMICAL RESISTANCE TEST



# ABOUT US



Since its inception in 1977, M.M. has been operating in the **glass fibre reinforced plastics (FRP)** industry, producing **high quality gratings and structures** (handrail systems, walkways, stairways, ladders, fences, gates, etc.). The intrinsic properties of FRP allow to create light, resistant and easy to install structures that do not require maintenance and are characterised by great versatility of use.

The company offers **customized solutions and additional services** such as technical design, structural calculation for composite materials, chemical and mechanical resistance tests, any type of cut to size, shaping and finishing.

Every phase of the company process, from design to production, from the quotation to the follow-up service, is focused on **customer satisfaction**.

**HIGH QUALITY RAW MATERIALS**

**CUSTOMIZED SOLUTIONS**

**RESEARCH AND INNOVATION**

## CUTTING AND SHAPING



## SURFACE TREATMENTS



## VERIFICATION OF PRODUCT CONFORMITY



# 06



## FENCE ELEMENTS

The spacing between the stanchions varies according to the type of grating used.

The stanchions can be anchored in concrete for a depth of at least 30 cm or fixed to the base unit using stainless steel base plates.

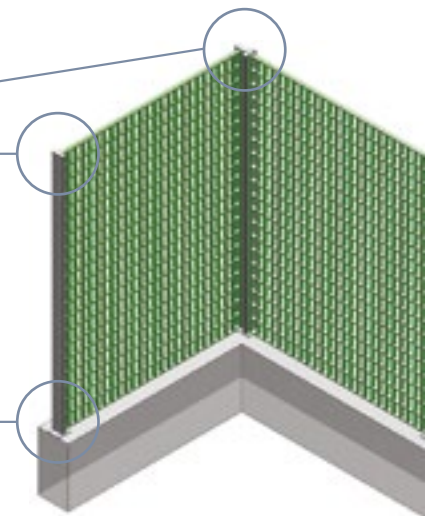

# FENCES

Fences are made with fibreglass gratings and profiles and are mostly suited for use in areas where **electrical isolation, resistance to chemical or atmospheric agents are required**.

They are also an excellent solution for the airport sector for their **non-magnetic and radiolucency properties**.

Standard colours are grey or green, but on request they can be supplied in different colours. The top extension arm is also available on request.

Our Technical Department can provide customized solutions for fences designed to meet particular customer needs both in terms of size and in terms of shape of the fence.

**MODULAR**

**DIELECTRIC**

**QUICK AND EASY TO INSTALL**

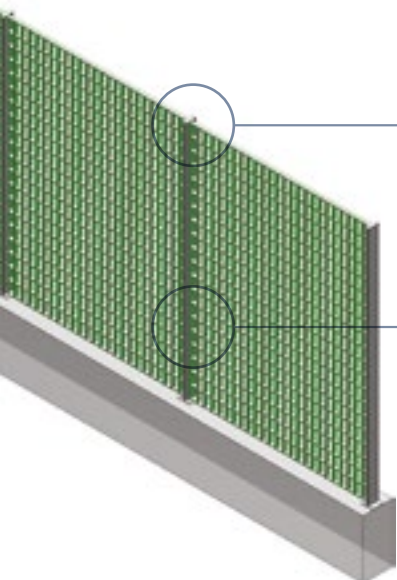

The top of the stanchions are closed with a plastic cap.

The panel is fixed to the stanchions with self-locking screws and nuts or anti-unscrewing nuts in AISI 316 stainless steel.

**CHOOSE THE PAINT FINISH FOR A BETTER AESTHETIC RESULT**

# FENCES

All fences are designed by the Technical Department in order to optimize the cost-performance ratio. They are made of **modular elements** and are factory **pre-drilled**, thus allowing quick and simple assembly operations.

## TYPE 01

GRATING	SCH60/25, mesh 100x60 mm, thickness 25 mm
PANEL SIZE	1.500x900 mm
FRP RECTANGULAR PROFILE	85x25x3 mm
DISTANCE BETWEEN STANCHIONS	1.525 mm

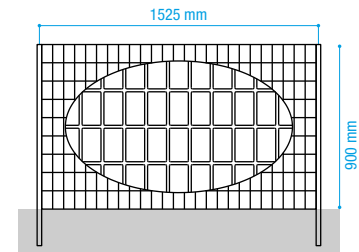

## TYPE 07

GRATING	SCH30/28, mesh 100x30 mm, thickness 28 mm
PANEL SIZE	2.000x1.500 mm
FRP RECTANGULAR PROFILE	85x25x3 mm
DISTANCE BETWEEN STANCHIONS	2.025 mm

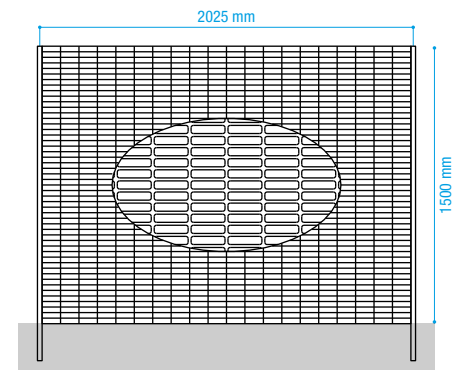

## TYPE 09

GRATING	SCH60/25, mesh 100x60 mm, thickness 25 mm
PANEL SIZE	2.000x1.500 mm
FRP RECTANGULAR PROFILE	85x25x3 mm
DISTANCE BETWEEN STANCHIONS	2.025 mm

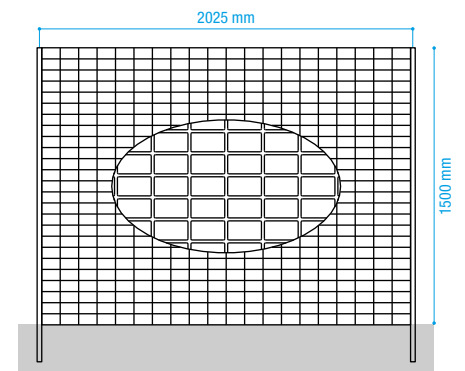

## TYPE 10

GRATING	SCH60/25, mesh 100x60 mm, thickness 25 mm
PANEL SIZE	1.500x2.000 mm
FRP RECTANGULAR PROFILE	85x25x3 mm
DISTANCE BETWEEN STANCHIONS	1.525 mm

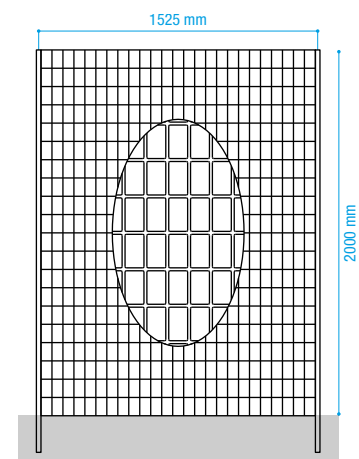

**TYPE 11**

GRATING	SCH38/25, mesh 38x38 mm, thickness 25 mm
PANEL SIZE	1.000x2.000 mm
FRP RECTANGULAR PROFILE	85x25x3 mm
DISTANCE BETWEEN STANCHIONS	1.025 mm

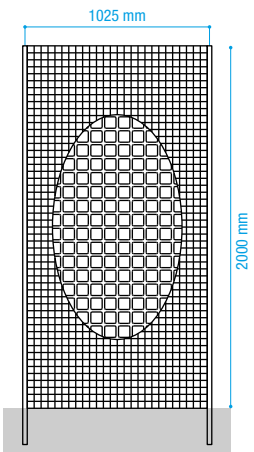

**TYPE 12**

GRATING	SCH38/25, mesh 38x38 mm, thickness 25 mm
PANEL SIZE	1.220x1.800 mm
FRP RECTANGULAR PROFILE	85x25x3 mm
DISTANCE BETWEEN STANCHIONS	1.245 mm

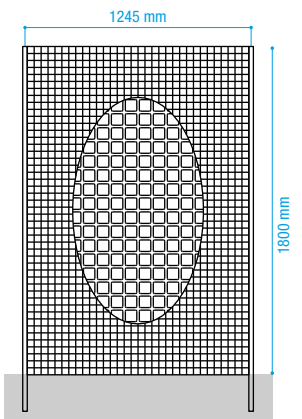

**TYPE 13**

GRATING	SCH30/28, mesh 100x30 mm, thickness 28 mm
PANEL SIZE	1.500x2.000 mm
FRP RECTANGULAR PROFILE	85x25x3 mm
DISTANCE BETWEEN STANCHIONS	1.525 mm

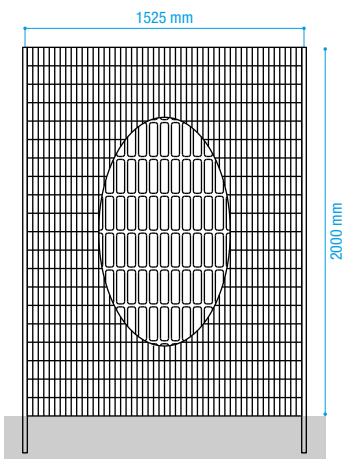

**STANCHION BASE PLATE**

CODE	56ASTAFFA9
SIZE	base unit 100x100 mm housing 77x19x250 mm
MATERIAL	stainless steel
WEIGHT	750 g

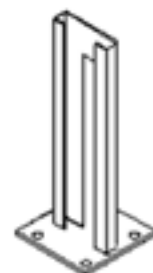

## **M.M. SRL**

ADMINISTRATIVE OFFICE AND PRODUCTION PLANT  
Via Antonio Zanussi, 300/302, 33100 Udine - Italy  
ph. +39 0432 522970 - fax +39 0432 522253

info@mmgrigliati.it - VAT No. and Tax Code: 02984500302

## PRODUCTION PLANT

Via Antonio Zanussi, 311, 33100 Udine - Italy

**[WWW.MMGRIGLIATI.COM](http://WWW.MMGRIGLIATI.COM)**

