

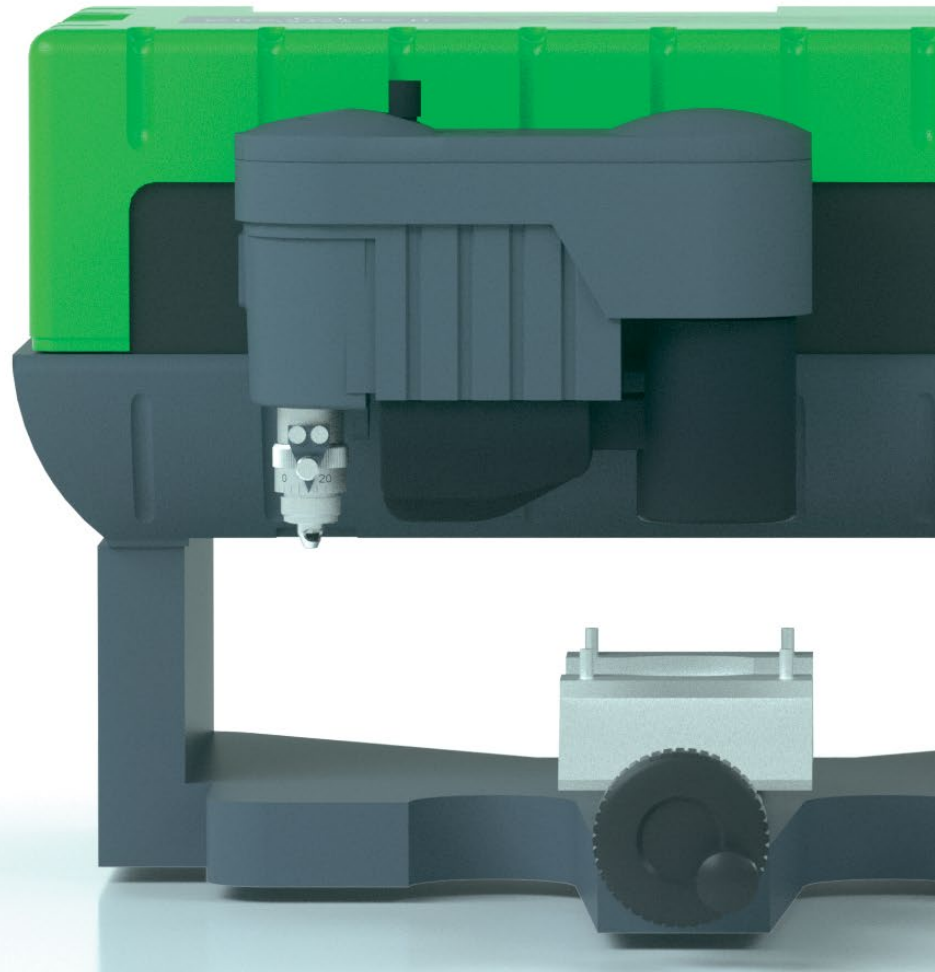

CNC STATION

IS200



GRAVOTECH
EXPRESSION OF THINGS



This industrial engraving machine has been a classic for more than 15 years for small part traceability, label and small signage engraving. The IS200 is compact and portable, perfect for busy workshops and mobile workers.

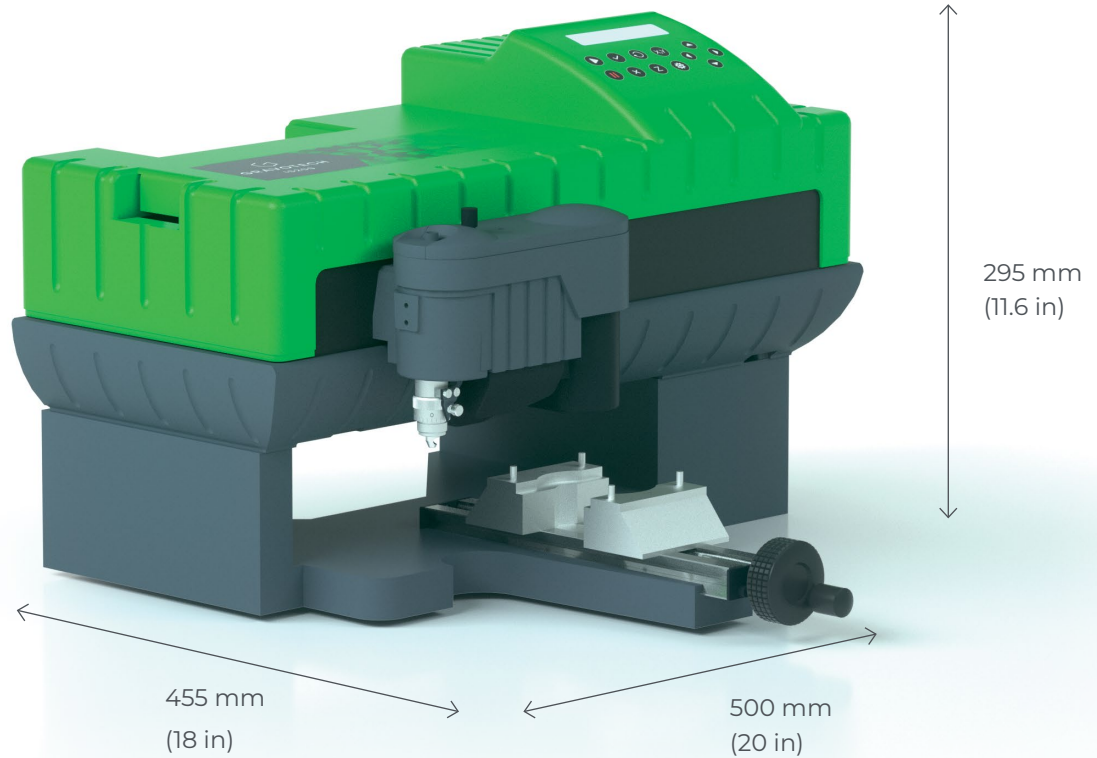

SMALL TRACEABILITY MACHINE

The IS200 engraving machine is designed for workshops and businesses. Its 80 x 225 mm (3 x 8,6 in) unrestricted working area combined with a 0.2 mm flatness tolerance makes it easy to work with oversized items. Easily engrave wood, plastic, and metal with the wide range of spindles available. The IS200s' open structure allows you to mark small parts for traceability. Deep and exact engraving for optimum readability.

COMPACT AND QUIET MACHINE, SUITABLE FOR OFFICES

With a footprint as small as 500 x 455 mm (20 x 18 in), the IS200 engraving machine is the size of a desk printer. It is fitted with a remarkably quiet DC motorized spindle that will work in your environment. Whether you are a professional sign maker, an administration or an institution, create on-demand labels, badges, identification signs, instruction plates, and more.

EASY TO TRANSPORT ENGRAVER

Thanks to its 20kg (44 lbs) weight and its compact dimensions the IS200 is the perfect multi-purpose engraving machine for portability. Take it for on-site demonstrations, fairs, exhibitions, markets, and it will ensure you will be noticed!

SEE OUR VIDEO



KEY FEATURES



Integrated LCD screen

The IS200 engraving machine is equipped with a high-quality LCD screen to ease the use of the machine.

Take direct control over the process and set-up your engraving parameters.

Save your parameters, start and pause the engraving, set-up the Z ref and more.

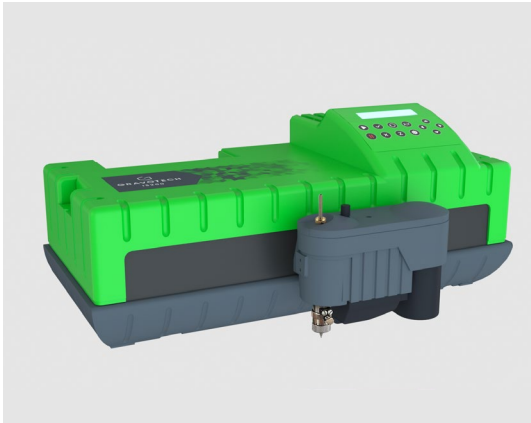

Industrial engraving machine

The IS200 machine has proven to be reliable across the years.

Whether you need to engrave, mill, or drill, it will get the work done with precision.

Do you have large parts to mark? Remove the base and mount the head securely in place to directly engrave on the part.



Complete engraving software

Add the Gravostyle™ engraving software to your engraving package to access unlimited possibilities.

Use the matrix mode for label engraving and save time, get the traceability module to mark scales and graduations and automatically update serial numbers.

Contact us for advice.

LEARN MORE ABOUT THE IS200



SOFTWARE

GRAVOSTYLE™



Expert software made by engravers for engravers

Gravostyle is a professional engraving and cutting software that puts Gravotech engraving expertise in reach. Benefit from advanced possibilities and save time! Unique features available: Braille, Photostyle, Print & Cut, and more.

Complete engraving process mastered

Due to our history of making engraving machines, we have a full understanding of the engraving process. Gravostyle is fully compatible with all of our technologies. The software/machine interaction streamlines and improves your day-to-day engravings with functions like Point & Shoot.

Gravostyle: unique software for laser and rotary

Are you already using Gravostyle on your rotary machine, and expanding your business with a laser? No need to learn how to use another software, switch in one click on the Gravostyle™ interface to set-up laser engraving!

SERVICE & SUPPORT



Training

Our training modules are designed to optimize your use of our solutions and are available for our full range of machines, software and accessories.



Technical support

We bring you local support in your language in more than 50 countries, where we have established presence directly and with our distribution partners.



Maintenance

Thanks to experience gathered with Gravograph and Technifor and our global presence in more than 50 countries with 150 Gravotech technicians and our distributor partners, we can offer you a wide range of services.

APPLICATIONS

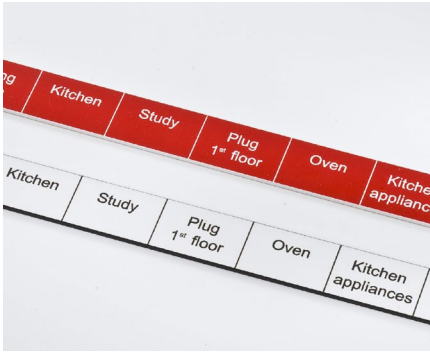

Electrical labels



Sign engraving



Gift engraving



Identification and equipment traceability



Express engraver



Personalizing and engraving jewelry

MATERIAL CHARACTERISTICS

		ROTARY	DIAMOND DRAGGING
Materials	Glass, Crystal	●	
	Leather	◀▶	
	Wood, varnished wood	◀▶	
	Acrylic, PMMA	◀▶	
	Plastics	◀▶	
	Anodized aluminum	◀▶	●
	Brass	◀▶	●
	Gold, silver, nickel, platinum	◀▶	●
	Metals	○	●

◀▶ = Cutting ○ = Engraving/Deep marking ● = Marking/Etching

MAKE YOUR SAMPLES



TECHNICAL DATA

	IS200
Technology	Rotary, scribing
Marking area max (L x H)	225 x 80 mm (8,6 x 3 in)
Spindle power	20W
Max object size (L x W x H)	Unlimited x 140 x 30 mm (5,5 x 1,2 in)
Max object weight	10 kg - 22 lbs
Machine dimensions (L x W x H)	500 x 455 x 295 mm (20 x 18 x 11,6 in)
Machine weight	20 Kg (44 lbs)
Type of spindle	Top load spindle
Noise	80 dB (A) +/- 2
Point & shoot	no
Operating temperature	5 °C (41 °F) - 40 °C (104 °F)
Connection to computer	USB
Maximum speed	25 mm/s (1 in/s)
Z stroke (Z travel)	15 mm (0,6 in)
Rotation speed	max 17 000 rpm
Tool diameter	4,36 mm (0,17 in)



web.us@gravotech.com

+1 800 843 7637

www.gravotech.us

GRAVOTECH, INC. (USA HEADQUARTERS)

2200 Northmont Parkway,
Duluth, GA 30096, USA

Follow us:

