

FLOATING TRIMMING UNIT – CLASSIC LINE

FLOATING V C

TECHNICAL DATA

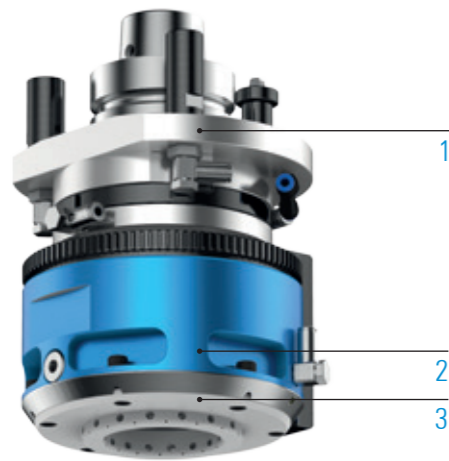

Lubrication
 Max. drive speed n_2
 Transmission ratio ($n_1: n_2$)
 Max. drive torque M_2
 Weight

Grease
 24,000rpm
 1:1
 8Nm
 about 4.5kg

STANDARD DESIGN

- 1  Machine connection
HSK - F63
- 2  Output spindle
Weldon $\varnothing 10/\varnothing 16$
- 3  50 Internal diameter of floating ring

ADDITIONAL OPTIONS: MODULAR DESIGN

1



MACHINE CONNECTION



 For further information see p. 106

2



OUTPUT SPINDLE



Weldon
 $\varnothing 10/\varnothing 16$

 For further information see p. 108

3



INTERNAL DIAMETER OF FLOATING RING

50

 Additional internal diameters of floating ring on request

MACHINING



Drilling



Milling

SPECIFICATIONS



1 Number of output spindles



0° Axis angle



360° C-angle



Grease lubrication

ORDER DIRECTLY



Inquiry form:
www.benz-tools.de/en/products