

# SoniXs MS-6

REVOLUTIONIZE YOUR  
END-OF-LINE [PACKAGING]  
PERFORMANCE

MOSCA



NONSTOP RESPONSIBLE  
NONSTOP RELIABLE  
NONSTOP INTELLIGENT  
NONSTOP PROGRESSIVE

Automatic Strapping Machine 

Mail Order & Logistics, Construction  
& Containers, Food & Beverage 

SoniXs Sealing Unit | Standard-6 

For PP and PET straps 

Lateral Position of Sealing Unit 

NONSTOP PERFORMANCE

# SoniXs MS-6

## AUTOMATIC SIDE-SEAL STRAPPING MACHINE

The SoniXs MS-6 is characterized by its side-mounted sealing unit, which protects against falling particles of dust or dirt and prevents downtime due to contamination. The side position allows lower conveying heights and flexible mounting of the strap dispenser.

This side seal machine is optionally available with an automatic double strap dispenser for almost non-stop operation. Thanks to a wide choice of frame sizes and strap widths, the machine works with 5 - 15 mm wide PP straps or 9 - 15 mm wide PET straps.

### TECHNICAL DATA

Performance:  
Up to 52 cycles per minute (550 x 500 mm)

Frame Sizes: (WxH)  
450 x 400 mm  
550 x 500 mm  
650 x 600 mm  
900 x 600 / 1,400 / 1,800 mm  
1,300 x 600 / 1,000 / 1,400 / 1,800 / 2,200 mm  
1,650 x 600 / 1,800 mm

Conveying Height:  
310 - 560 mm (Standard)  
360 - 1,110 mm (optional increased working height)

Straps:  
PP straps: Width: 5 - 15 mm  
Thickness: 0.4 - 0.9 mm  
PET straps: Width: 9.5 - 15 mm  
Thickness: 0.4 - 0.66 mm

Strap Coil Dispenser:  
Core diameter: 200 mm (optional 406 mm PET)  
Core width: 190 mm (optional 150 mm PET)

Electricity:  
Voltage: 100 - 240 V, 50 / 60 Hz, 1L+N+PE  
(others on request)  
Power consumption: approx 0.2 kW

Weight: (without options)  
205 - 300 kg

### STANDARD FEATURES

SoniXs Ultrasonic sealing unit in standard-6 version

Can be integrated into most production lines

Easy accessibility and tool-free disassembly of strap path components

Dispenser variably mountable

Hinged table top made of stainless steel

Adjustable strap tension via control panel

Easy operation via digital display in the control panel

Manual strapping release via pushbutton in the control panel

Stepless turnable control panel (0° - 180°) for many-sided operation

4 castors

Extremely low energy consumption

CE marking inclusive conformity declaration

### OPTIONS

Flexible foot switch for manual strap release

Pneumatic hold-down device

Pneumatic side-pusher

Sealing unit for low products

Automatic adjustment of the strap tension by package height detection

Two- or three-part signal light (LED)

Low strap detection with signal in the control panel

Signal exchange via 16-pole contact plug to integrate into fully automatic production lines

Fully automatic strap coil change by double strap dispenser

Middle rollers

Special conveying heights

### DIMENSIONS / WORKING WIDTH MACHINE (in mm)

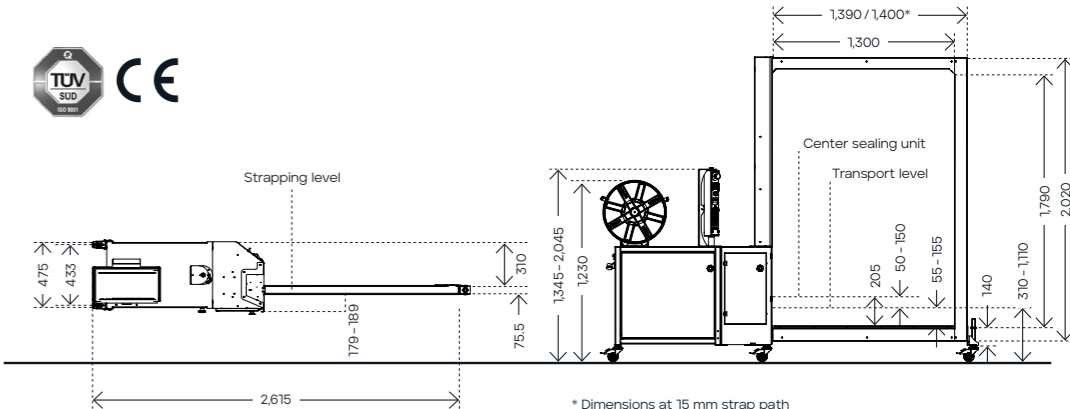

### HOLISTIC SUPPORT WITH THE MOSCA SYSTEM

Suitable consumables available directly from Mosca. Can be combined with Mosca maintenance contracts - all from one source.

### CONTACT US FOR A PERFORMANCE CONSULTATION!

mosca.com

Mosca GmbH  
Gerd-Mosca-Straße 1 · 69429 Waldbrunn

info@mosca.com · +49 6274 / 932-0