

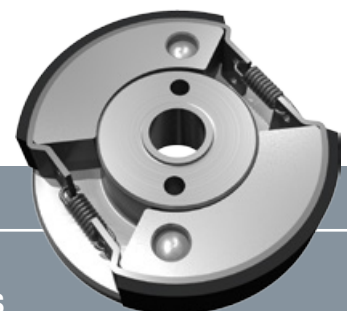

Maschinentechnik

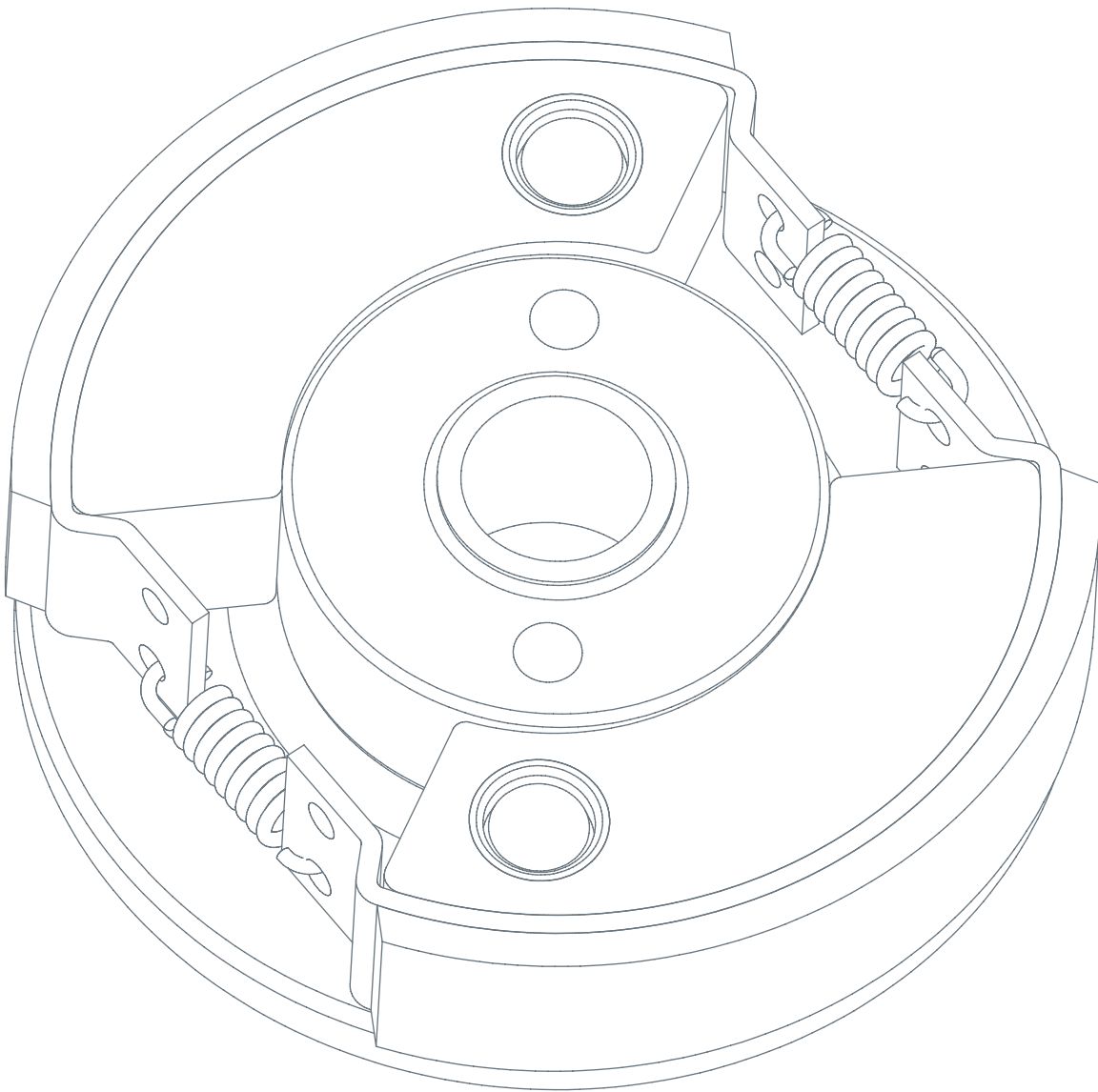

Controlled dynamics

Centrifugal clutches

Experts in our field since 1982.

Strong clutches do not slip – we are driven by centrifugal force!

Amsbeck Maschinentechnik GmbH is a leading manufacturer of clutches and brakes based on the simple and effective functional principle of centrifugal force.



We revert to the principle, first deduced in 1669 by Christian Huygens, that a radial force acts on rotating masses. This force rises with the square of the angular velocity and is calculated according to the formula:

$$F_r = m \cdot \omega^2 \cdot r \text{ [Nm]}$$

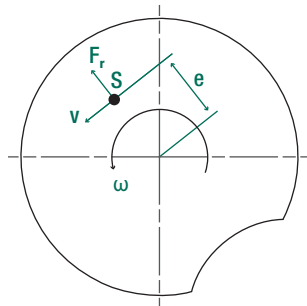

Combined with a suitable frictional partner, we use this force to build up a torque according to the formula:

$$T = F_r \cdot \mu \cdot r \text{ [Nm]}$$

This together with the speed causes an activation of the clutch without additional measurement readings, control and external energy. Additional expenditure and costs for electrical, hydraulic or pneumatic control units can frequently be avoided.

Since 1982 we have been developing and customising a large variety of different executions for clutch applications with axial or radial transmission.

Our team of highly qualified and experienced employees produces and sells clutches all over the world from the Everswinkel location in the heart of the Münsterland region.

The usual sizes work on an effective diameter between 60 and 250 mm and reach torques from 2 to 4500 Nm.

We offer advanced, tried-and-tested and long-lasting drive solutions at extremely good value for money and for various different markets. Our products stand for dynamics and safety.

Tell us what you require – and we will provide the solution swiftly and competently.



Susanne Weritz, manageress

Centrifugal clutches

Functional principle

Guided weight elements set in rotation are exposed to a radial force component, which accelerates them outwards. This force is compensated by spring forces up to the defined engagement speed.

At engagement speed, the friction linings are in contact within the housing and the torque build-up at the housing begins. Increasing the speed leads to quadratically increasing forces and thus to the torque increasing. The clutch is in slide operation and the application is accelerated to nominal speed by way of rotation. Once the nominal speed of the application has been reached, slide operation ends and the torque is frictionally transmitted.

As long as the spring force outweighs the centrifugal force, the system will work without contact and without losses. So as not to impair the function, any grease, oil and moisture are to be kept away from the friction surfaces.

Through varying the spring design, the friction material, the overall size, the number of parallel elements and the operating speed, the engagement speed and torque are determined and adapted to the respective case of application.

Engagement

The engagement speed is generally dependent on the operating speed of the drive machine and the power to be transmitted. Since the power of a centrifugal clutch increases quadratically as the speed rises, a minimum operating speed of the drive system is necessary.

The engagement of a centrifugal clutch describes the speed at which the mass of the centrifugal weights, through the centrifugal forces acting on these, overcomes the retention force of the springs. By choosing springs of different strengths, which retain the centrifugal weights for different amounts of time, the engagement speed can be varied.

Based on our many years of experience, the engagement speed is set so that a higher torque than necessary is reached at operating speed. This ensures that the clutch is protected from slipping, even in the case of a temporary drop in speed.

Powers and dimensions

Size/nominal diameter	Standard borehole d [mm] ¹⁾	d max. [mm]	External diameter D [mm]	Width B [mm] ²⁾	Md1 [Nm] at nE 750 and nB 1500 [1./min]	Recommended power P1 [kW] ³⁾	Md1 [Nm] at nE 1250 and nB 2500 [1./min]	Recommended power P2 [kW] ³⁾	Md1 [Nm] at nE 1500 and nB 3000 [1./min]	Recommended power P3 [kW] ³⁾
60	10; 15; 20	20	60	20	1,7	0,1	4,8	0,6	6,9	1,1
80	15; 17; 19,05; 20; 25; 25,4	25	80	20	3,8	0,3	10,5	1,4	15,2	2,4
90	15; 19,05; 20; 25; 25,4; 28	30	90	20	9,1	0,7	25,1	3,3	36,1	5,7
100	14; 19,05; 20; 23; 25; 25,4	30	100	20	10,9	0,9	30,2	4,0	43,4	6,8
110	19,05; 20; 25; 25,4; 30	40	110	25	24,2	1,9	67,1	8,8	96,7	15,2
125	19,05; 20; 25; 25,4; 30; 35	45	125	30	47,4	3,7	131,7	17,2	189,6	29,8
140	19,05; 20; 25; 25,4; 30; 35	45	140	30	59,0	4,6	164,0	21,5	236,1	37,1
165	25; 25,4; 30; 38; 42; 48	50	165	30	106,0	8,3	294,4	38,5	423,9	66,6
200	35; 38; 42; 50; SAE 7,5"/11,5"	75	200	30	277,6	21,8	771,1	100,9	1110,3	174,4
250	45; 50; 55; 60; 63,5; 65; 70; 75; SAE 10"/11,5"	80	250	30	720,5	56,6	2001,3	262,0	2881,9	452,7

¹⁾ Taper boreholes and special dimensions are also possible if requested by customer.

²⁾ The clutch power can be increased by changing the width.

³⁾ Motor power determined applying a safety factor 2. Final design of the clutch by Amsbeck.

Example of engagement behaviour of a centrifugal clutch

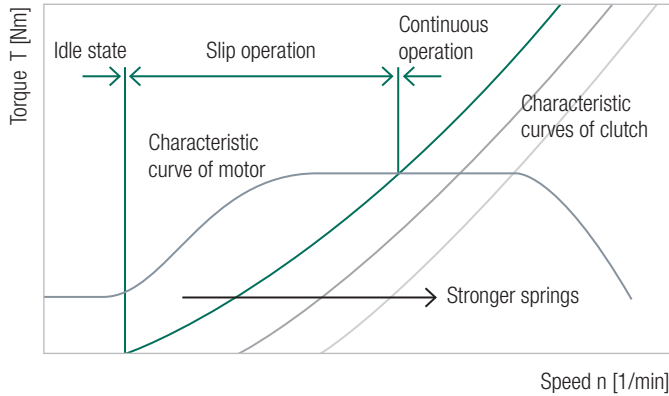

Heat

Friction generates heat, and a centrifugal clutch converts the friction work during the slide phase completely into heat. The organic friction linings used by Amsbeck absorb a very small part of the heat, almost the entire amount of heat is absorbed by the housing and adjacent parts or released into the environment through thermal conduction.

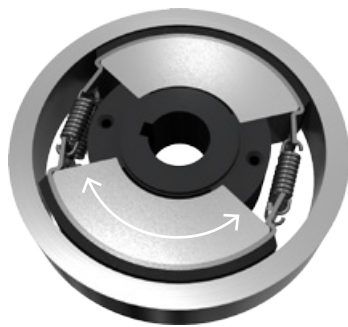

Profile-guided execution

In the Amsbeck basic execution, the centrifugal elements are guided on the hub via a „dovetail profile“ and the torque is transmitted **independently of the direction of rotation**.

The friction linings are bonded on backing plates and these are tensioned with the springs via the centrifugal weights. Under speed, the entire friction surface is applied and used.

Because of the torque support on the dovetail guide, a servofactor results which is dependent on the angle of this guiding.

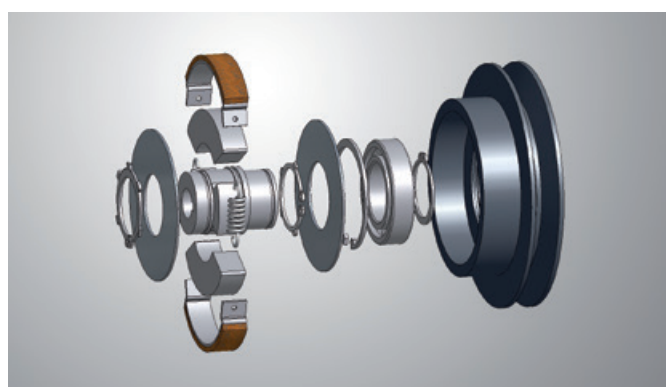

Exploded view of the dovetail execution



Turning jaw execution

With the turning jaw execution, the centrifugal elements are guided on one side with low backlash via a pin at a pivotal point. The solid supporting plate of the pins increases the damping properties of the clutch and, in conjunction with the bearing of the centrifugal weights, a low-vibration and low-noise running is ensured. Thanks to the self-reinforcement similar to a duplex drum brake, very high torques are reached in one direction of rotation. No self-reinforcement takes place in the opposite direction of rotation. As a result of this, the torque capacity goes down to approx. 50 %. Applications that require both directions of rotation can be implemented through changing the jaw arrangement and can reach a torque capacity of approx. 75 %.

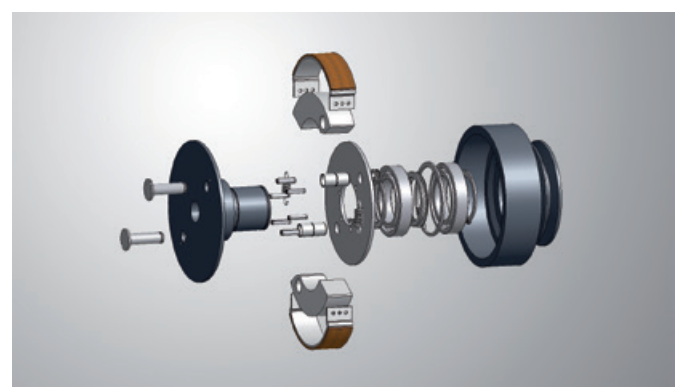

Exploded view of the turning jaw execution

Amsbeck means variety

Centrifugal clutches

with mechanical and automatic belt tensioner

Amsbeck has various executions in the range for various different drive engineering requirements. In addition to axial and radial output possibilities, combinations of different clutch systems are also available to you for the purpose of obtaining optimal torque transmission.

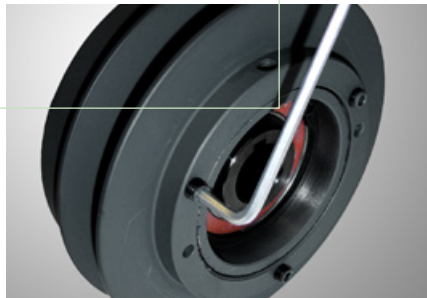

Centrifugal clutch with mechanical belt tensioner



Centrifugal clutch with automatic belt tensioner

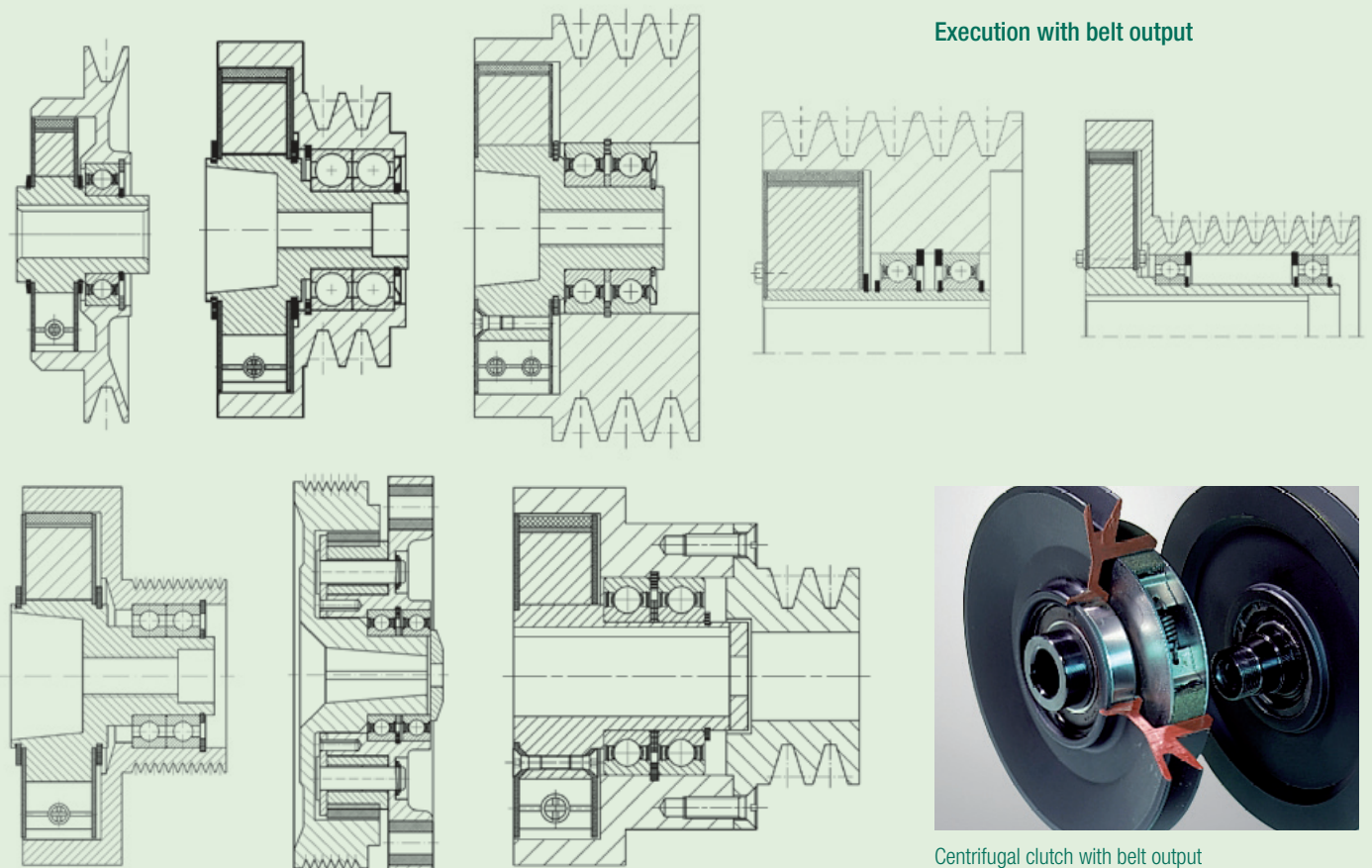

Centrifugal clutch with belt output

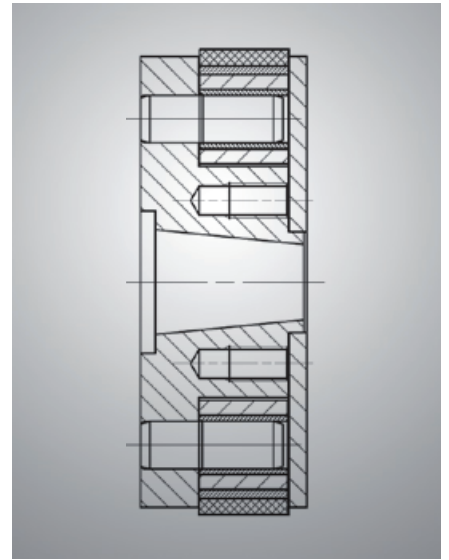

Execution without housing

Execution with axial output

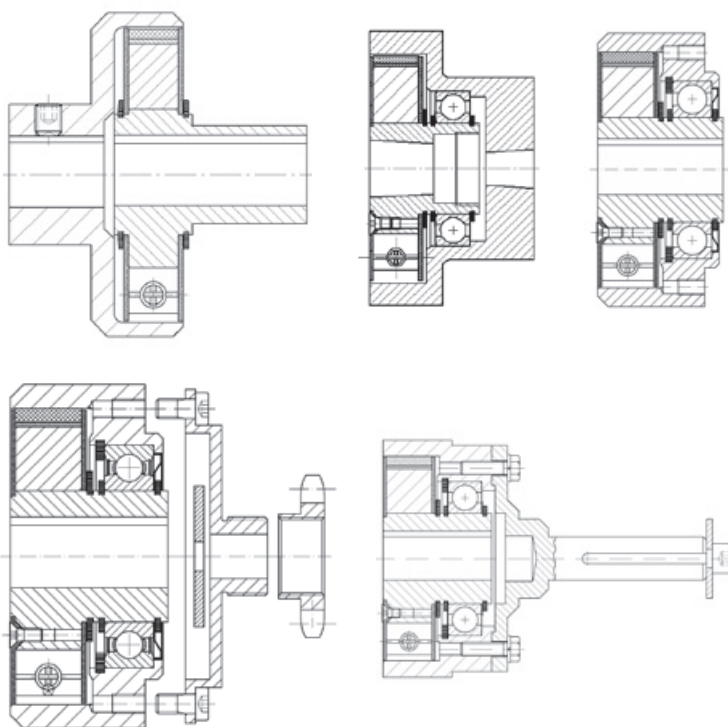

Clutch combinations

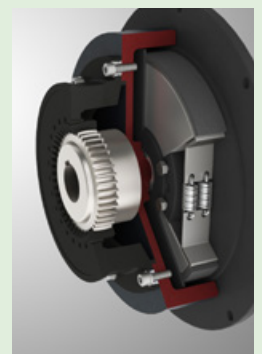
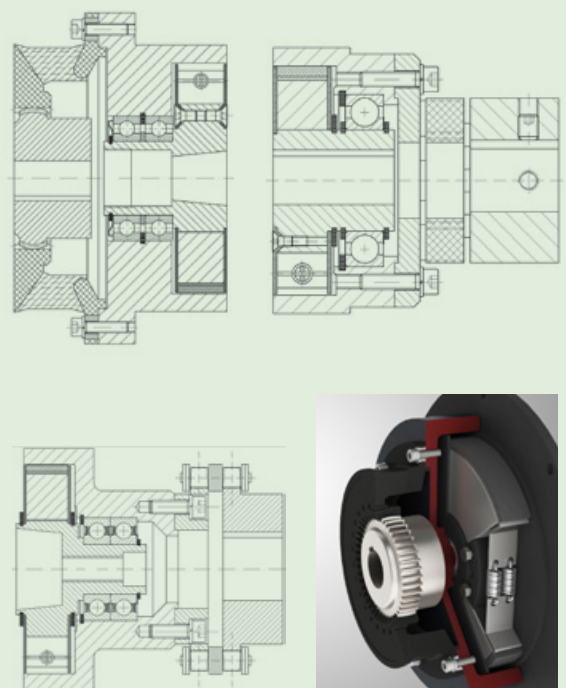

Centrifugal clutch combined with highly flexible clutch

Fields of application



Construction machines

Selected applications

Our various fields of application

- Construction machinery
- Agricultural machinery
- Cooling technology
- Compressor technology
- Municipal vehicles
- Racing
- GALA construction equipment



Racing



Cooling technology



Municipal vehicles

Quote request for centrifugal clutches



Quote request from company: _____

Contact: _____

Telephone: _____ Fax: _____

Email: _____ Website: _____

Type no. known Type no.: _____ Quantity: _____ Price/item: _____

Type no. unknown Brief description of application: _____

Manufacturer, motor type: _____

Idling speed [rpm]: _____ Drive power: kW HP _____

Max. moment [Nm at rpm]: _____ Operating speed [rpm]: _____

Engagement speed [rpm]: _____ Working machine: _____

Connection to motor

Cylindrical shaft Diameter: _____

Groove width: _____

Length: _____

Conical shaft Diameter: _____

Taper ratio: _____

Taper angle: _____

Taper length: _____

Flange Pitch circle-Ø: _____

Number of boreholes: _____

Borehole-Ø: _____

Centering: _____

Output through

cylindrical borehole Diameter: _____

Groove width: _____

Length: _____

Belt SPA SPB SPC SPZ Other: _____

Diameter: _____

Quantity: _____

Counter pulley-Ø: _____

Axial distance: _____

Hole pattern Pitch circle-Ø: _____

Thread: _____

Centering: _____

Please note other connections or outputs here: _____

Quantity: _____ Price/item: _____

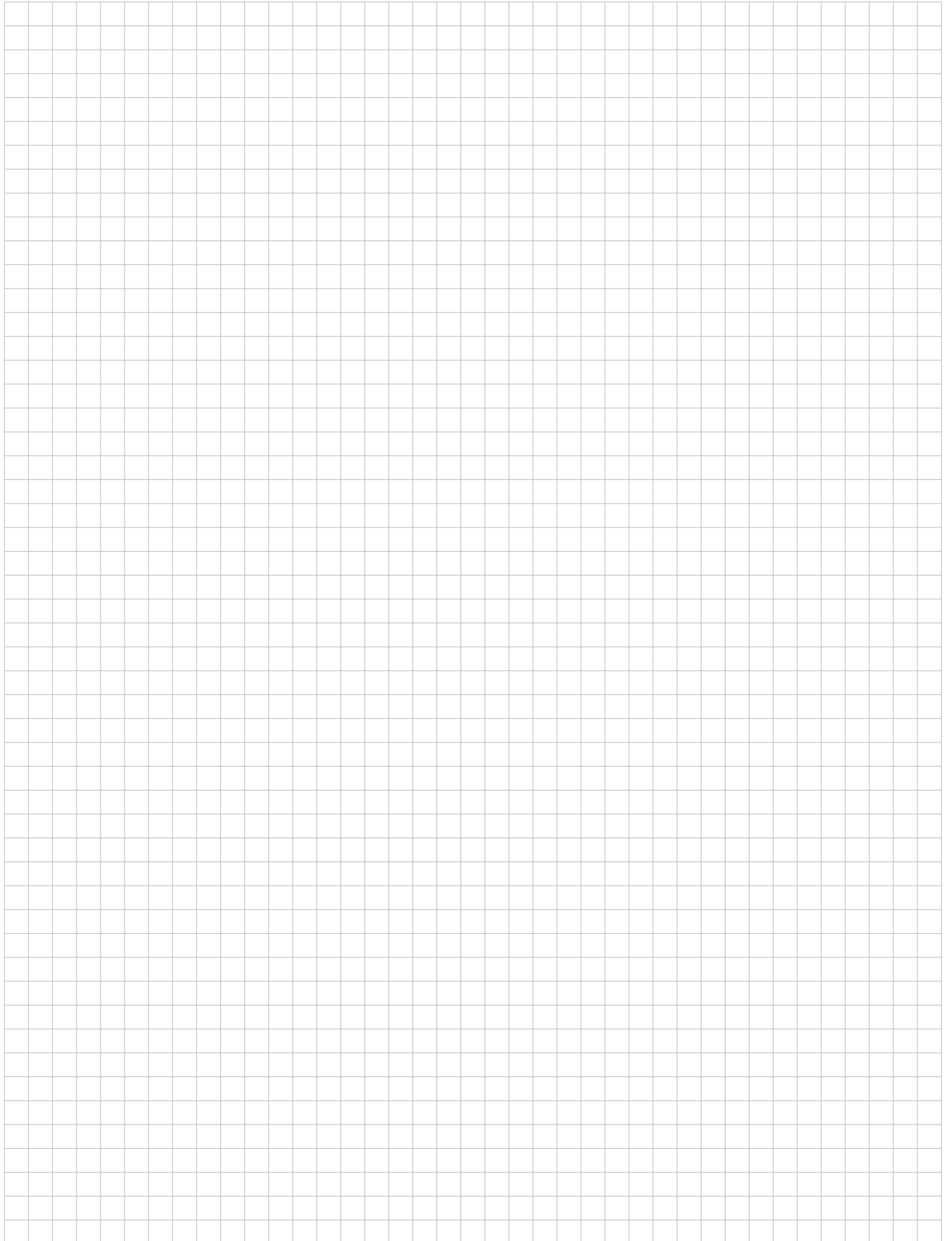

Do you need special solutions?

We like a new challenge – please contact us.

Further product information available



Find out also about our:

Centrifugal brakes | Gearboxes | Hydraulic multiple disc clutches | Electromagnetic multiple disc clutches

Amsbeck Maschinenteknik GmbH
Boschweg 15 | 48351 Everswinkel

Phone +49 (0)2582 66812-0
Fax +49 (0)2582 66812-101

info@amsbeck-mt.de
www.amsbeck-mt.de

We are certified in accordance with:
Testing standard ISO 9001:2008
Certificate reg. no.: 09 100 50 59