

Zumbach

SWISS PRIME MEASURING SINCE 1957

PROFILEMASTER® SPS 50/80/100/150



In-Line Profile Measurement Systems
for Hot / Cold Steel Applications

TECHNOLOGY

The PROFILEMASTER SPS system is based on the laser triangulation principle using four up to eight light-section sensors. Each sensor consists of a laser transmitter and an industrial CMOS camera. The sensors are arranged in an octagonal metrology to obtain complete information about the product shape. The optics of the point laser emitter contain a cylindrical lens that generates a line. The CMOS cameras extract the position of the laser line internally using a peak detection algorithm, resulting in a sub-pixel resolution that enables high acquisition speeds.

Thanks to its unique concept, precise and reliable measurements are guaranteed for virtually any shape, regardless of torsion. Likewise, an advanced software toolbox is available for measurements such as angles, widths, thicknesses, radii, depths, distances, diameters or deviation from the nominal value. The profile shapes can be easily imported using existing DXF files.

Advantages – Main Features

- With 4 up to 8 cameras, any shape can be captured and measured
- Real-time monitoring of complex profiles
- Roundness/polygonality mode of round products
- Surface fault detection (SFD) thanks to high sampling rate
- High sampling rate up to 1000/second
- Compilation of a 3D model thanks to high sampling rate
- Highly accurate measurements
- Detects process problems in an early stage
- Reliable operation in harsh mill conditions up to 1200° C
- Simple cleaning, short maintenance
- Logging of all production data for QC department
- Network capability with a higher-level system
- Eliminates the need for subsequent manual measurements

MEASURING PRINCIPLE

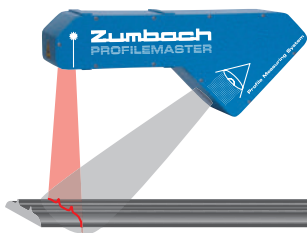

The measuring principle is based on 2D laser triangulation respectively light-sectioning technology. Four or more lasers illuminate the product surface and the associated matrix cameras capture the light contour from an oblique angle. A powerful and fast computer and the PROFILEMASTER software combine the captured segments into an orthogonal profile cross-section.

ROI CALCULATION EXAMPLE

Case Study:

Significant cost savings are achievable due to fast and precise measurement of profiles in hot condition. Our customer shared statistical data about his production with us:

The technical down time has been reduced by 2% with the help of the PROFILEMASTER SPS system. The biggest savings are achieved while setting up the rolling stands during product changes. The advantage of contour measurement makes it possible to bring the product into the desired tolerance more quickly. Thus, it takes less time and scrap to set up the products which results in extra production capacity:

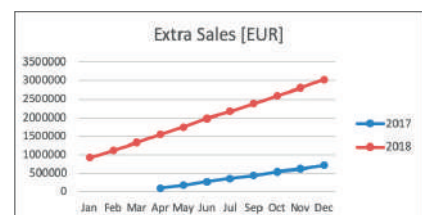
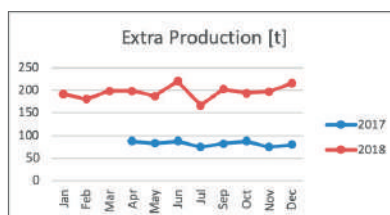
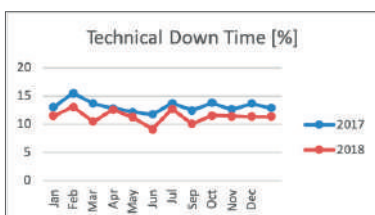

The customer's PROFILEMASTER SPS system was installed in March 2017. Since the commissioning, the customer was able to generate extra production. Over 21 months, our customer achieved extra sales worth 3 Mio. € due to the use of PROFILEMASTER SPS system. For this case, the ROI (return of investment) was achieved in a couple of months only!

IN-LINE REBAR MEASUREMENT

Our Rebar Software option allows the measurement of the characteristic dimensions of a Rebar product. It works within the standard PROFILEMASTER software during in-line production (hot or cold).

The rebar algorithm generates a section profile consisting of an inner and an outer contour on which measurements can be applied:

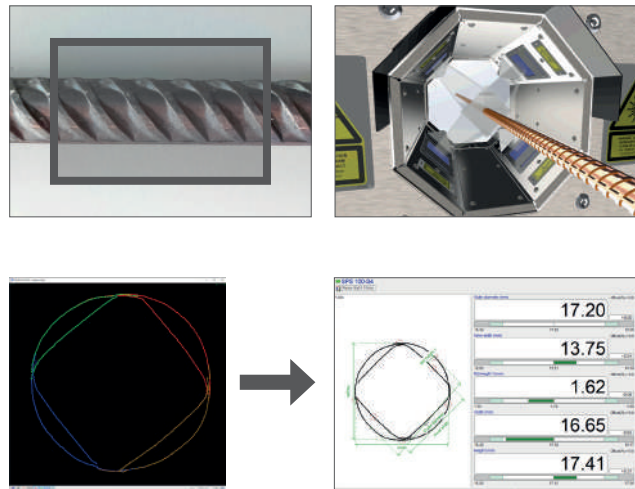

This process is repeated all along the bar. The characteristics can be plotted as a function of the length as strip charts. The following example shows the rib height (mm/in.) along the product length (m/in.):

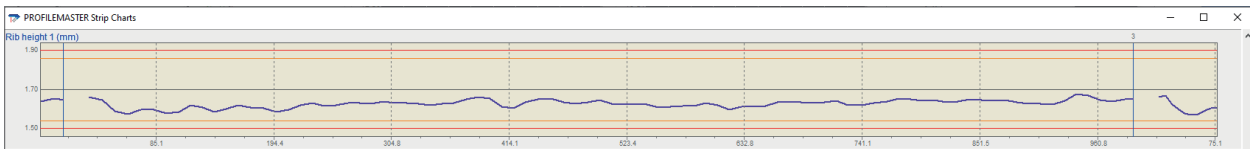

The results can be stored in the PROFILEMASTER Data Base for later analysis (process/quality control).

Thanks to the multi-strand capabilities of Profilemaster rebars can be measured in parallel on up to 4 strands:

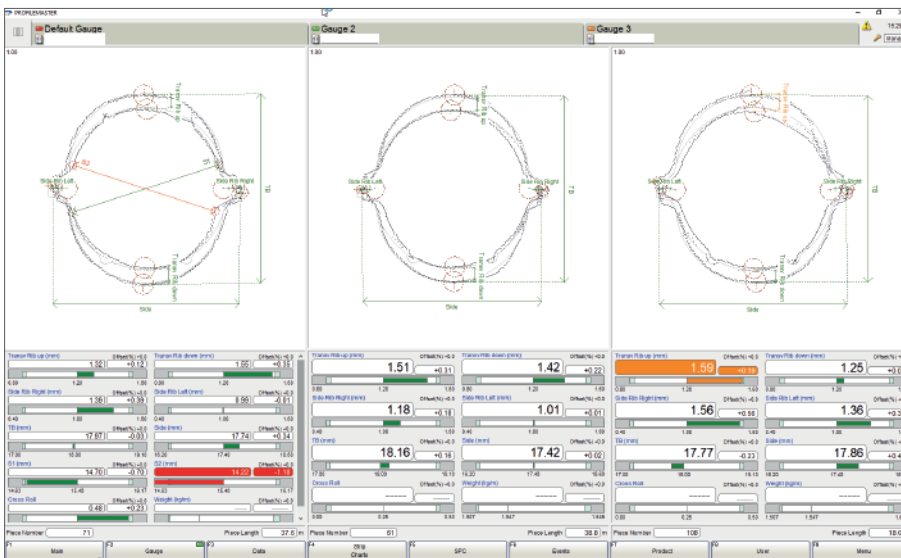

Typical/characteristic dimensions:

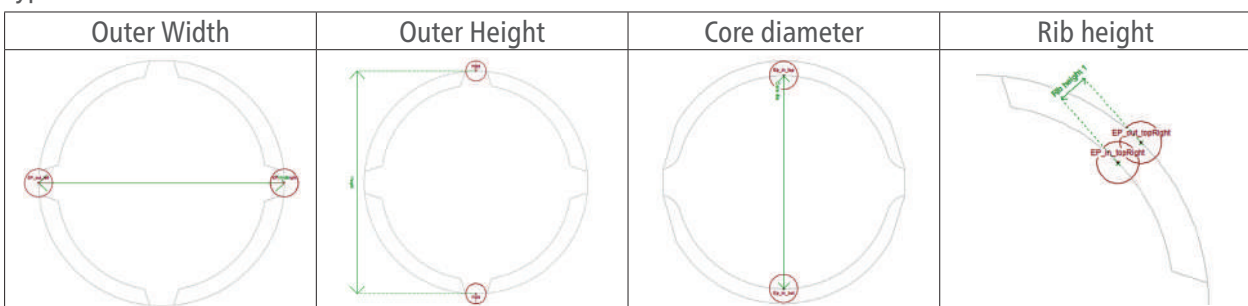

DIMENSIONS SPS SYSTEM

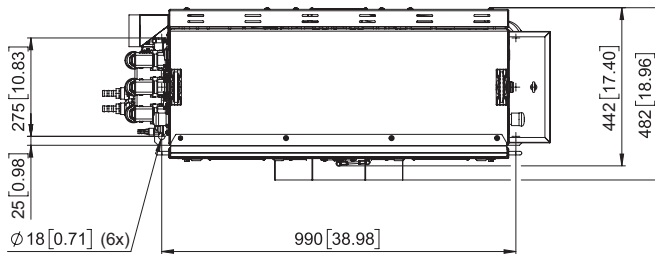
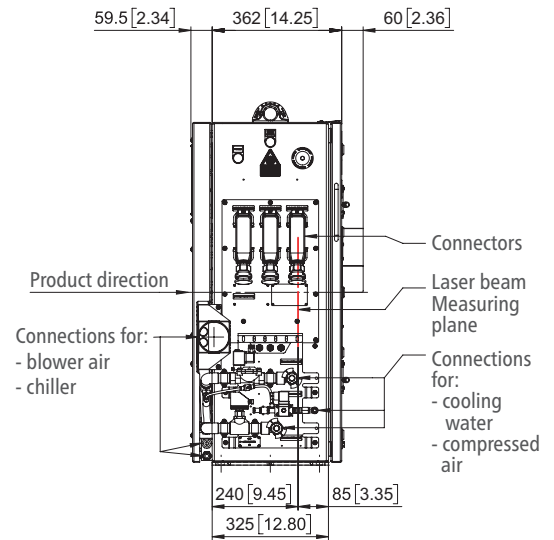
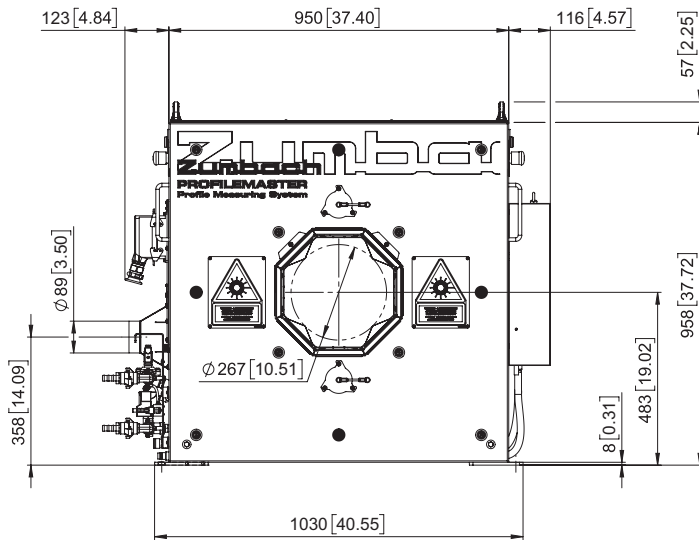

Attention:
Product guides must not be fixed on the measuring unit

Approximate weight: 190 kg (419 lbs.)

Dimensions in mm (inch)

Model PROFILEMASTER	SPS 50-Sx	SPS 80-Sx	SPS 100-Sx	SPS 150-Nx
Number of cameras	4...8			
Measuring field	Ø 50 mm (1.79 in.)	Ø 80 mm (3.15 in.)	Ø 100 mm (3.94 in.)	Ø 150 mm (5.9 in.)
Largest product dimensions (depends on worst case off-centre position)	Round: Ø 45 mm or Square: 32 x 32 mm (Ø 1.77 in. or 1.26 x 1.26 in.)	Round: Ø 72 mm or Square: 51 x 51 mm (Ø 2.83 in. or 2 x 2 in.)	Round: Ø 90 mm or Square: 64 x 64 mm (Ø 3.54 in. or 2.52 x 2.52 in.)	Round: Ø 135 mm or Square: 95 x 95 mm (Ø 5.31 in. or 3.75 x 3.75 in.)
Min. object diameter	Ø 5 mm (0.2 in.)	Ø 10 mm (0.39 in.)	Ø 10 mm (0.39 in.)	Ø 20 mm (0.79 in.)
Scanning frequency	up to 1 KHz			
Display resolution	0.001 mm (0.00004 in.)			
Repeatability (1 σ)	0.002 mm (0.000078 in.)		0.003 mm (0.00012 in.)	
Accuracy, typically within	+/- 0.010 mm (+/- 0.00039 in.)	+/- 0.015 mm (+/- 0.00059 in.)	+/- 0.020 mm (+/- 0.00078 in.)	+/- 0.025 mm (+/- 0.00098 in.)
Product temperature	max. 1200 °C (2192 °F)			
Ambient temperature	Operating: -20...+45 °C (-4...113 °F), Transport/Storage: -20...+60 °C (-4...140 °F)			

System Components

Measuring unit

Profile measuring system

Local processing and operation unit LPO

PROFILEMASTER SPS 50-Sx/80-Sx/100-Sx/150-Nx

Processing and display unit CPO

Control cabinet with basic control buttons

Blower unit

Industrial computer with latest operating system and screen

Cooling unit

Purging air supply for the laser/camera windows

To be supplied by the customer

Chilled water for inside conditioning of the measuring unit

3-phase (and 1-phase) power supply, compressed air, cooling water

• Specifications are subject to change without notice



WORLDWIDE CUSTOMER SERVICE AND SALES OFFICES

Headquarter:
Zumbach Electronic AG
P.O. Box
CH-2552 Orpund
SWITZERLAND
Tel.: +41 (0)32 356 04 00
sales@zumbach.ch

BENELUX, sales@zumbach.be
CHINA P.R., sales@zumbach.com.cn
CZECH REPUBLIC, jvorlicek@zumbach.cz
FRANCE, ventes@zumbach.com.fr
GERMANY, verkauf@zumbach.de

INDIA, sales@zumbachindia.com
ITALY, zumit@zumbach.it
SPAIN, gestion@zumbach.es
TAIWAN, info@zumbach.tw
UNITED KINGDOM, sales@zumbach.co.uk

North American Headquarter:
Zumbach Electronics Corp.
140 Kisco Avenue
Mount Kisco, NY 10549-1407
Phone +1 914 241 7080
USA
sales@zumbach.com



PROF.002.0002.EN AVR.2022

