

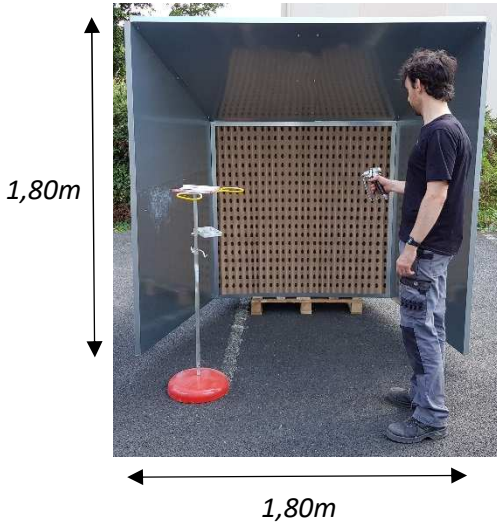

PAINT MODUL'

Compact & Modular spray booth



- **Delivered in kit** with drawings, blower and motor
- For **small or medium size parts, workshops, occasional or industrial painting**
- **Low electrical consumption** = 1,1kw/h
- **Low noise / low vibration** = 900rpm
- Airflow : **6500m³/h** per box (for 0,5m/s)
- **Up to 3 stages of filtration** (*overspray, dust and/or VOC/smells*)
- **Adapted to any kind of spraying** :
Solvent paints, water based paints, varnishes, UV, resins, gel coat etc.
- **Easily moveable** (can be put on wheels)
- **Easy extension** : (multiple paint modules can be combined)

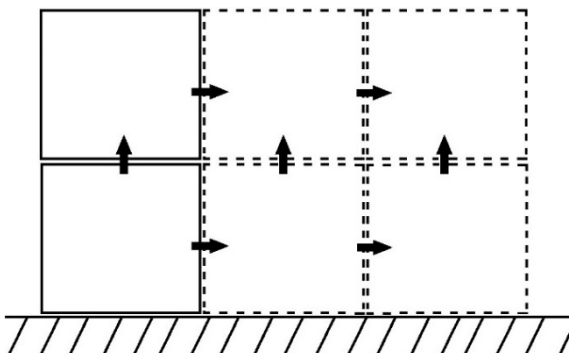

Options :

- single 220v or three phase 380v motor
- Atex blower
- kit for installation of 2 or 3 stages of filtration
- extraction D450mm x L2500mm
- wheels
- filters for wet or dry particles

Box = 1,25m x 1,25m (front dimension)

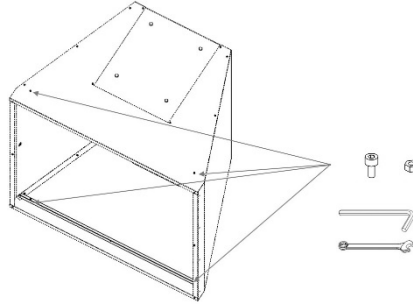

Paint Modul' « Simple » = 1,80m x 1,80m

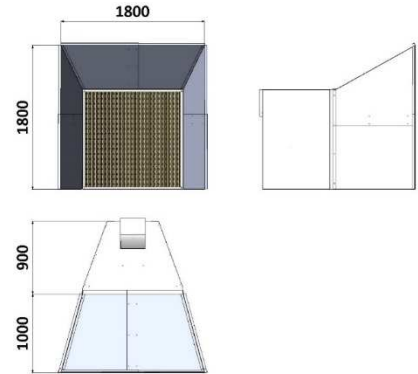
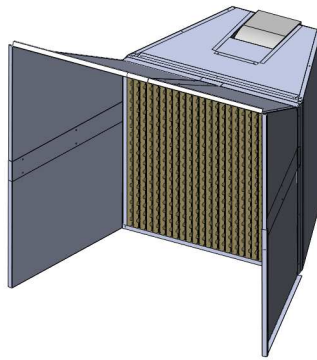

Paint Modul' « Double » = 3,05m x 1,80m

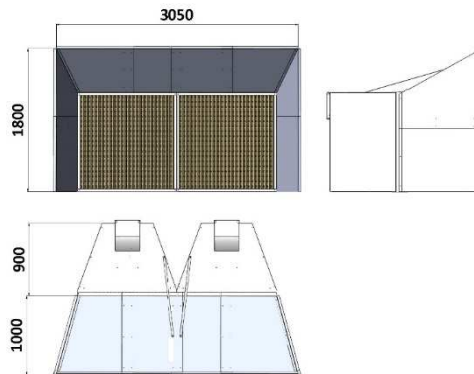
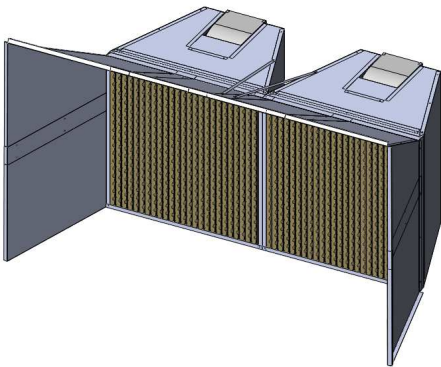

Other configurations :

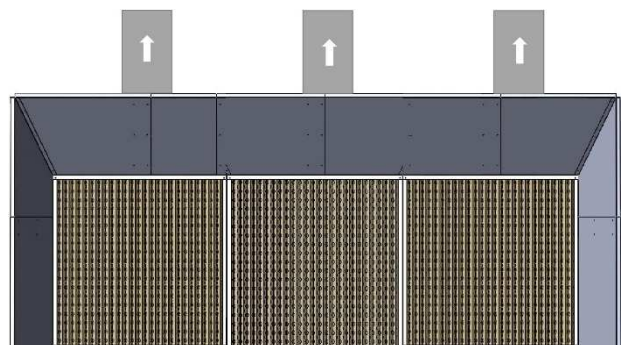
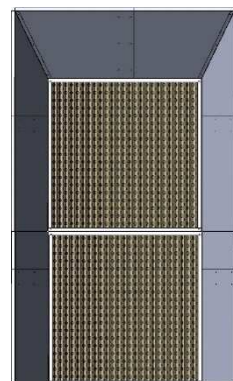



PAINT MODUL'

Compact & Modular spray booth

WOOD : Varnishes, Lacquers



Furniture / Carpentry / Cabinetry / Violin / Musical instruments

STEEL / METAL : Paints



Car parts / Wheels / Bikes / Helmets / Ironwork / Ferronnerie / Electrical motors / Goldsmith

PLASTICS : Prototypes / Models / 3D printing

COMPOSITES : Polyester resins / Gelcoat / Simultaneous projection

GLASS : Decoration / Bottling

LEATHER : Pigmentation / Tannery