



CONTACT WELDING UNITS

D1Q, D2Q, D3Q „Quickchange“
Silver graphite contact
welding unit

CONTACT WELDING UNITS

for industrial switchgear

Ultra productive process modules

Bihler contact welding units are designed for process-reliable mass production of contact components with very high stroke rates of up to 800 welds/min. With the 'Quickchange' system, retooling time is reduced by over 90% compared to conventional units.

Broad range of applications

The compact process modules can be efficiently used in a variety of areas: from IT to control engineering, from low voltage engineering to medium and high voltage engineering. They cover a broad range of applications both with regard to the semi-finished products which can be processed and the various contact sizes.

Electrical contact components for industrial switchgear

Information technology

Control engineering

Low voltage engineering

Medium and high voltage engineering

Semifinished products

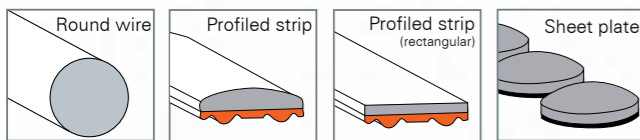

Finished contact elements

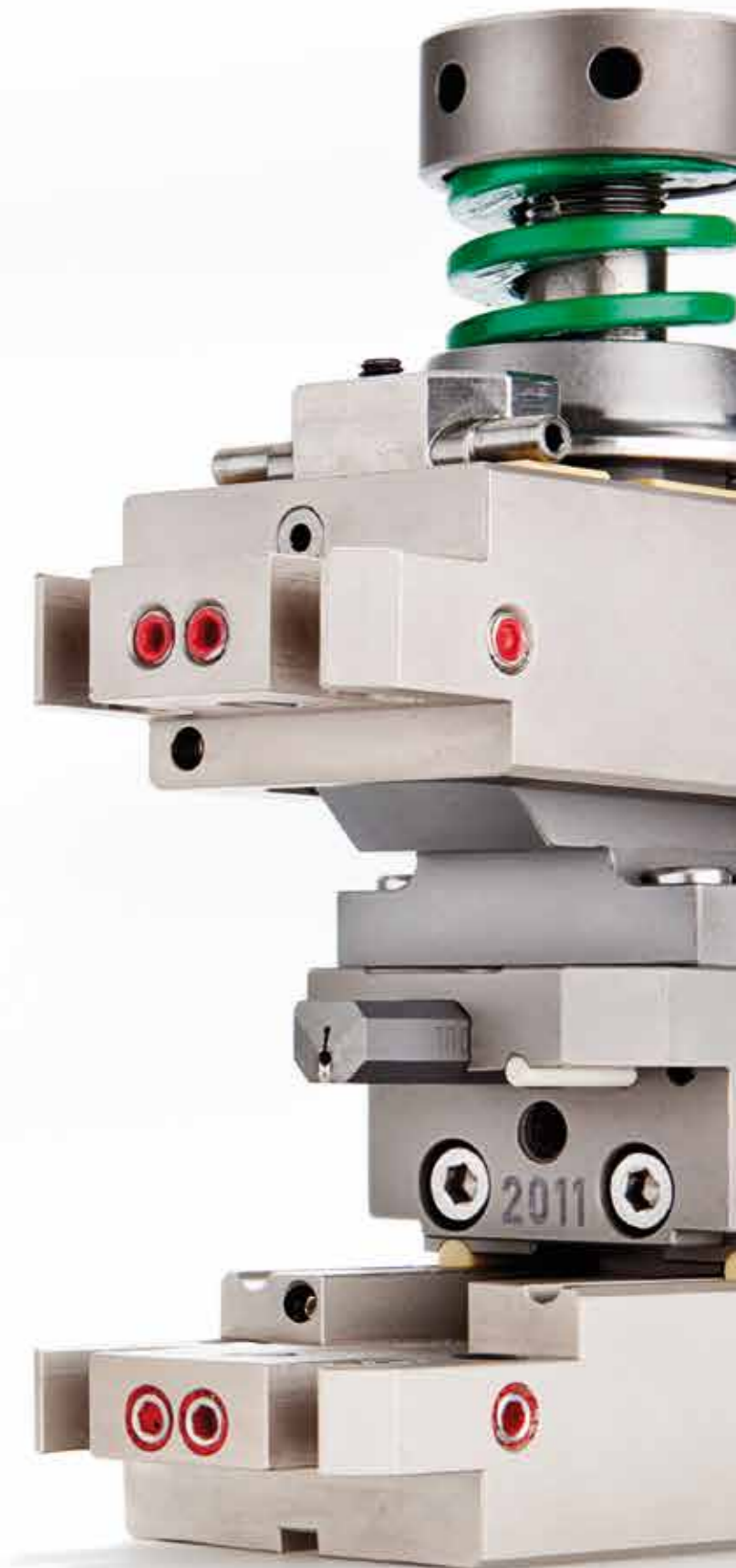
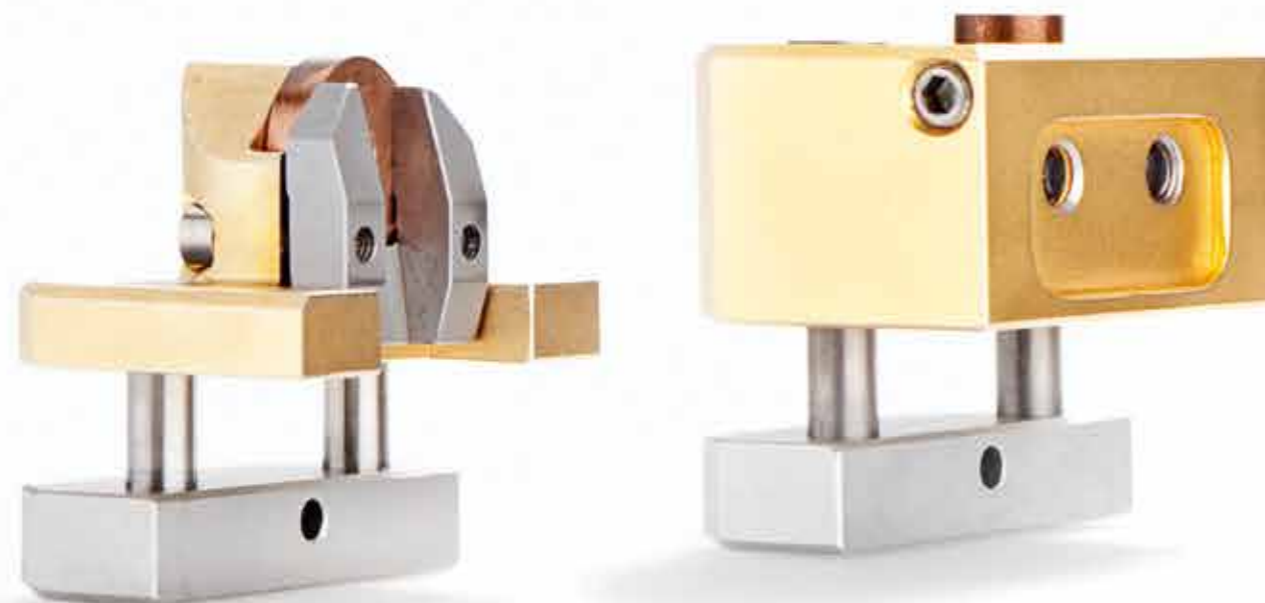

CONTACT WELDING UNITS

with 'Quickchange' retooling system

Ultra dynamic, flexible application and minimum retooling times

The 'Quickchange' process modules D1Q, D2Q, D3Q are designed for welding contact material from semifinished products. Profile shapes include round wire, profiled strips, rectangular strips and sheet plates made from all weldable contact material alloys, such as Au, Ag, Pd, Pt, etc. Further areas of application include resistance soldering.

Complete modular systems

The D1Q, D2Q, D3Q units are complete systems with a modular concept. They cover all of the required process steps right through to the finished welded contact element, including contact feeding, transport, cutting and positioning.

All processing steps in one system

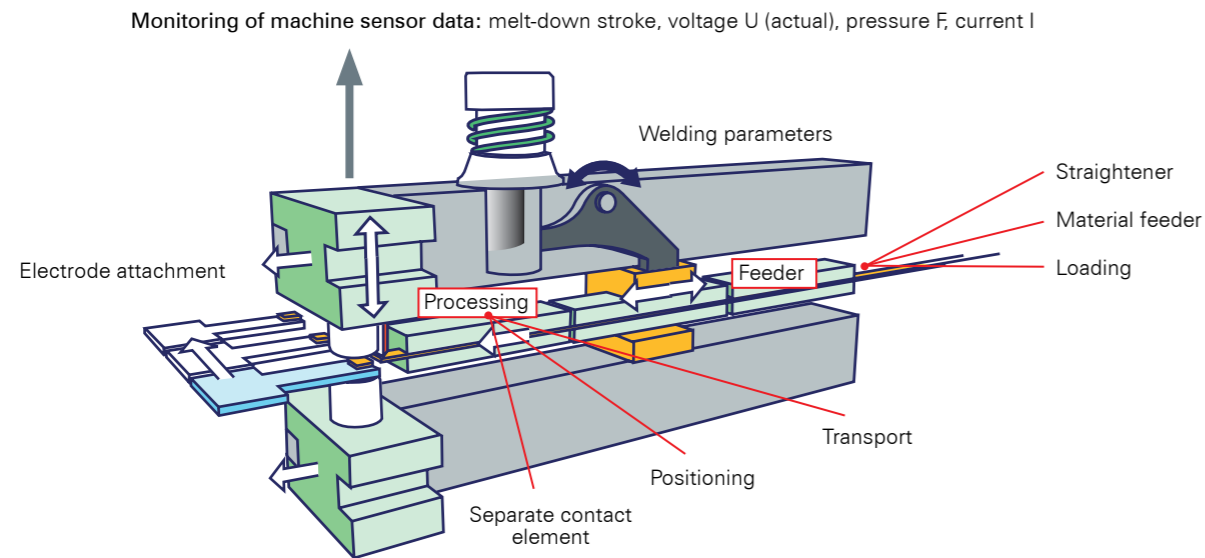

Key advantages

Maximum production speeds

- Up to 800 welds/min. are possible

Minimum retooling times

- Change of contact length (cutting length) in < 1 minute
- Electrode change in < 2 minutes through preset electrode subassemblies (pin electrode, profile electrode, turntable)
- Change to another contact size in < 10 minutes
- Change to another contact shape (e.g. profiled strip to round wire) in < 20 minutes thanks to modular concept

Flexible use

- Processing of round wire and profiled wire with one gripper system
- Blade cutting and electrode cutting with one gripper system
- Variable electrode holder to cover different applications



User-friendly handling

- Infinitely adjustable weld pressure. Spring preload setting can be read directly off the scale
- Electrode opening measurement: Quick and flexible settings via eccentric tappet or change part
- Feeder length: variable settings are possible via stop bar (compatible devices, can be replaced without disassembling other parts)
- Lateral guide (electrode arm): easy and infinite adjustment via eccentric tappet
- Full compatibility with older generations of contact welding units
- Rapid-clamp devices for media feed and measuring lines

Maximum quality for reliable production

- Preset subassemblies, change parts and corresponding setting gauges
- Recording of actual welding voltage (measurement position close to welding electrode)
- High quality tools, change parts and documentation for service and maintenance in clearly organised 'stackable box'
- Precise and reliable horizontal feed of semifinished products
- High wear resistance of all active parts (TIN coatings, carbide materials)
- Protected voltage measuring lines (integrated in electrode arm)
- Defined lubrication points (for easy service and maintenance)

Technical data

Type	Cut type	Contact geometry	Material dimensions*** max. (mm)	Productive capacities max. (welds / min.)
*D1Q E/M	Electrode cut Blade cut	Round wire Profiled strip	ø 1,8 x 3,0 3,0 x 0,8 x 3,0	800 400
D1Q K	Blade cut	Profiled strip (rectangular)	3,0 x 1,5 x 3,0	400
*D2Q E/M	Electrode cut Blade cut	Round wire Profiled strip	ø 3,0 x 5,5 5,0 x 1,7 x 5,5	400 350
D2Q K	Blade cut	Profiled strip (rectangular)	5,0 x 2,5 x 5,5	300
D3Q K**	Blade cut	Profiled strip (rectangular)	8,5 x 3,5 x 8,5	120

*essential for profiled strip or round wire **for soldering applications ***Diameter x cutting length; width x height x cutting length
Special applications on request (e.g. contact welding unit for micro contacts)



CONTACT WELDING UNITS

'Quickchange' product range



Unit dimensions

Type	Dimensions* LxWxH (mm)
D1Q E/M	190/400 x 40 x 133
D1Q K	240/450 x 46 x 133
D2Q E/M	250/440 x 58 x 190
D2Q K	340/520 x 68 x 190
D3Q K	475/725 x 95 x 287

* Length without straightener / with straightener and microswitch; height at max. feed

UNIT VARIANTS

Round wire, profiled strip, rectangular strip



Electrode cutting with round wire



Blade cutting with profiled strips



Contact transport with rectangular strips

Electrode cutting with round wire

Contact material feed – Contact element cut with welding electrode – Subsequent positioning on the carrier material – Welding process.

Blade cutting with profiled strips

Contact material feed – Contact element cut with blade – Transport in welding electrode and vacuum holding – Subsequent positioning on the carrier material – Welding process.

Contact transport with rectangular strips

Contact material feed – Contact element cut with blade – Position-precise feed of the contact part via transport system to welding point – Subsequent positioning on the carrier material – Welding process.

Special applications (on request)

- For profiled strips and round wires that are welded longitudinally (in the feed direction) onto the carrier material.
- For externally fed sheet plates (individual contact elements).
- For microcontacts

COMBINATION POSSIBILITIES

Electrodes / Contact transport



Profile/pin



Profile/turntable



Profile/Profile



Pin/pin (K-variant)

CONTACT WELDING UNIT

for silver graphite materials

Maximum process reliability and exact reproducibility

The contact welding unit is designed for welding contacts made from silver graphite materials (AgC). Thanks to the integrated cleaning station, any graphite residue is removed from the electrode contact surfaces after each weld, significantly increasing the electrode service life. Undefined conditions in the welding process are avoided. Each weld can be perfectly reproduced.

Key advantages

- Flexible use
- High production speeds of up to 180 welds/min. are possible
- Processing of profiled strips
- Individual feeding of contact plates

Function

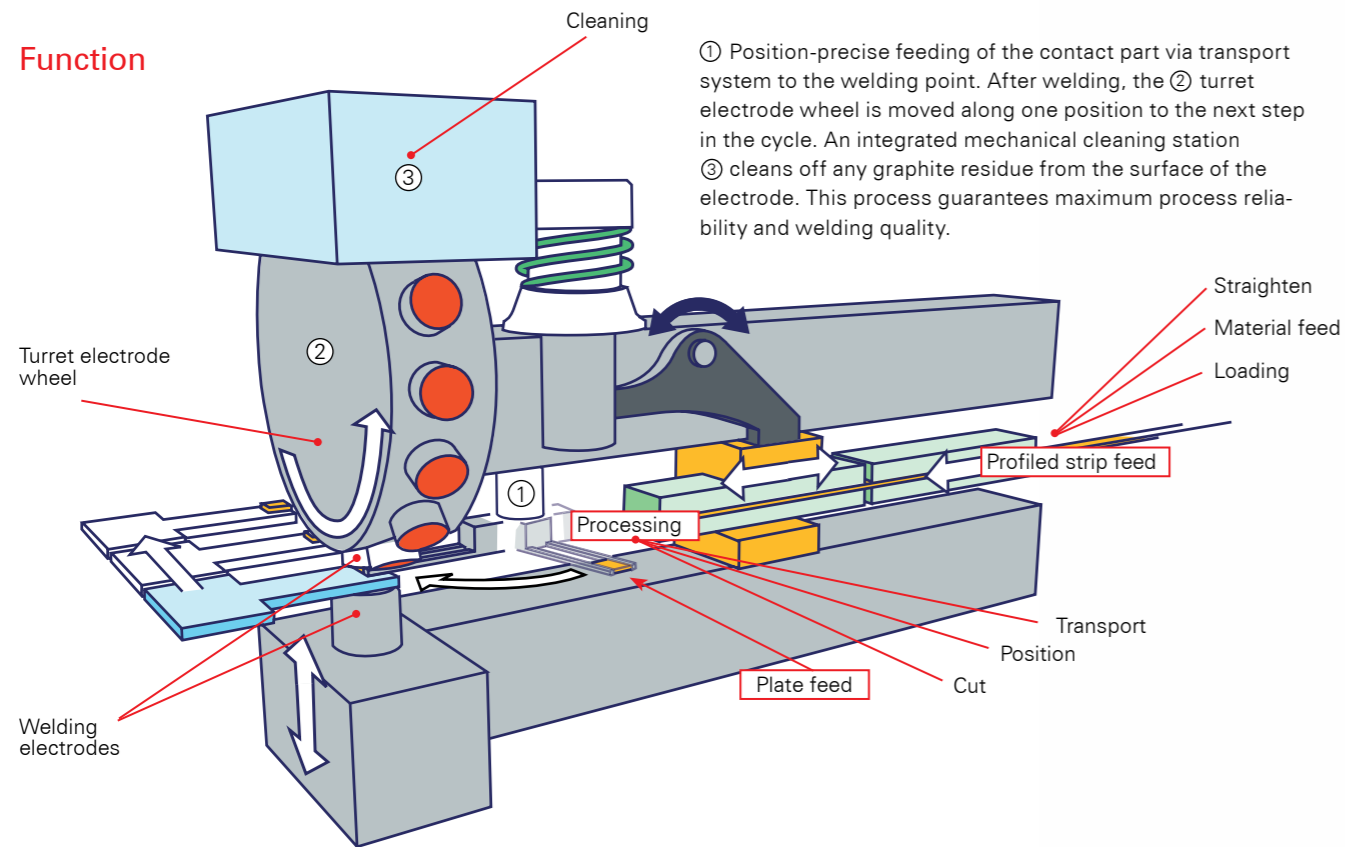

Technical data

Material	Cut type	Contact geometry	Material dimensions max. (mm)	Productive capacities max. (welds / min.)
AgC	Blade cut -	Profiled strip (rectangular) Sheet plate	5,0 x 2,5 x 5,5	180
AgC	Blade cut -	Profiled strip (rectangular) Sheet plate	8,5 x 3,5 x 8,5	120



NC CONTROL

for contact welding units

NC control for flexible deployment

The NC control serves to perform cycle-independent movements. All contact welding units can therefore be adjusted independently of the slide movement of the press or other mechanically generated pulses and can be independently operated. The advantage? Through optimally adjusted movement processes, the closing speed of the electrode can be reduced to avoid deformation of the welding auxiliaries on the lower side of the contact. All motion profiles can be freely programmed by the higher-level welding control unit B 5000.

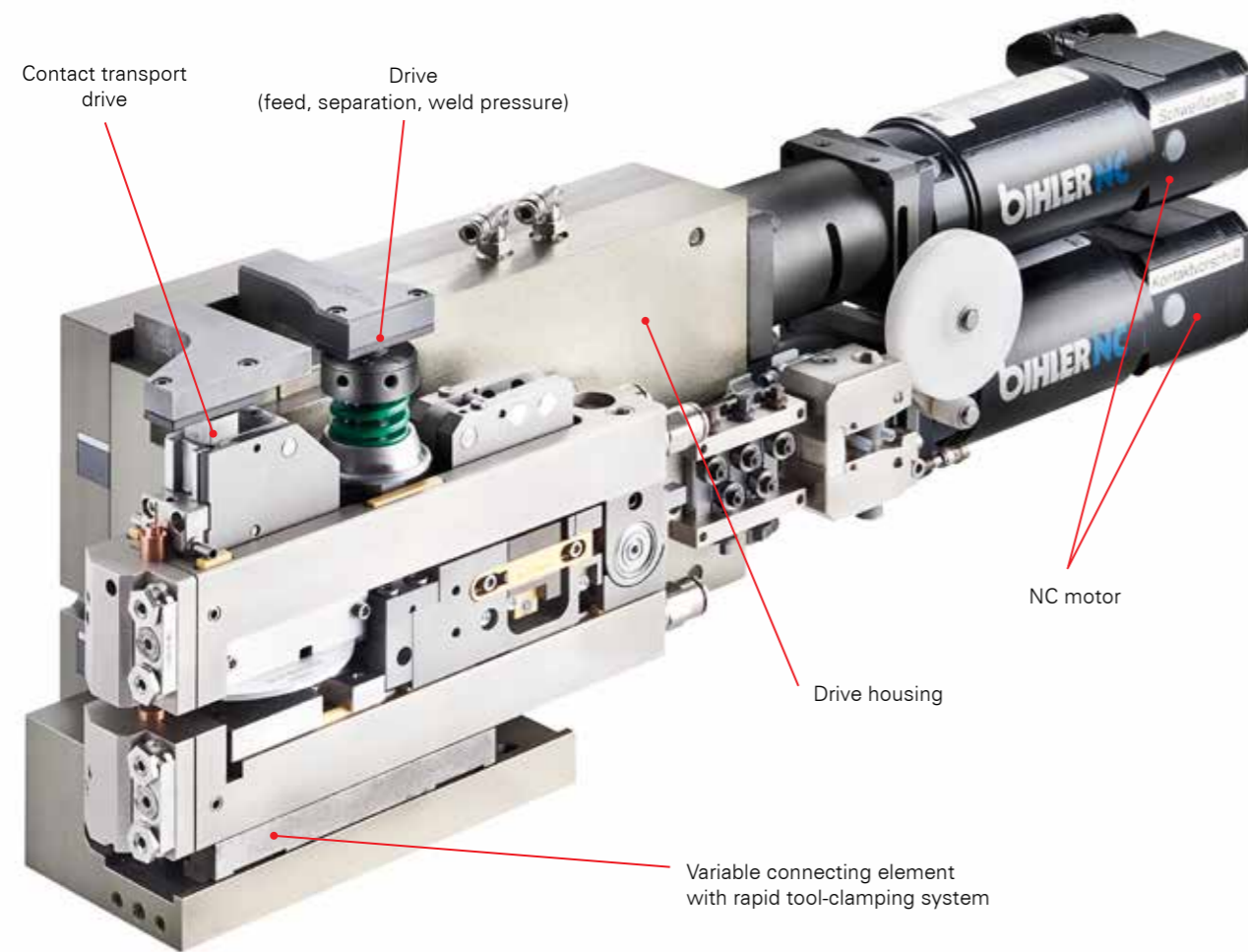

Otto Bihler Maschinenfabrik GmbH & Co. KG

Lechbrucker Str. 15

87642 Halblech

GERMANY

Tel.: +49(0)8368/18-0

Fax: +49(0)8368/18-105

info@bihler.de

www.bihler.de